



**OUTLINE DESIGN SPECIFICATIONS  
FOR  
PHASE-IV**

(APRIL 2019)

**DELHI METRO RAIL CORPORATION LTD.  
Metro Bhawan, Fire Brigade Lane,  
Barakhamba Road, New Delhi – 110 001**

## **Table of Contents**

<b>S.No.</b>	<b>Description</b>	<b>Page No.</b>
1	Introduction	1
2	Outline Design Specifications for Viaduct	3
3	Outline Design Specifications for Elevated Stations	34
4	Outline Design Specifications for Double Decker Structure	54
5	Outline Design Specifications for Cut & Cover Section	93
6	Outline Design Specifications for Bored Tunnel	143

## INTRODUCTION

With the introduction of Phase IV the total length of Delhi Metro will exceed 450 Kms. Proposed route of Phase IV construction are listed below :-

S No.	Description of Corridor
1	Janakpuri – Majlis Park (included)
2	Majlis Park (excluding) – RK Ashram
3	Inderlok - Indraprastha
4	Terminal-1 IGI Airport – Saket (excluded)
5	Tuglakabad – Saket (included)
6	Lajpat Nagar – Saket G Block
7	Majlis Park - Maujpur
8	Rithala – Bawana - Narela

The Outline Design Specification comprises of Viaduct, Elevated Station, Double Decker, Cut & Cover and Bored tunnels for Phase-IV.

The broad parameters covered in this specification are listed below:

### General

- 1) Material Parameters (Concrete, Reinforcement steel, Structural Steel, Prestressing bars, etc.)
- 2) Design Parameters
- 3) Loading Consideration (Dead Load, Super imposed Dead Load, Footpath Live Load, Railway Vehicular Load, Temperature Loads, etc.)
- 4) Load Combinations
- 5) Allowable stresses
- 6) Design Methodology
- 7) List of Design Codes to be followed

### Elevated Structures (Viaduct, Elevated stations & Double Decker)

- 8) Design Specification for Prestressed Structure
- 9) Design Specifications for Steel/Composite structure

**Underground Structures (Cut & Cover and Bored Tunnels)**

- 10) Tunnel Profile
- 11) Cross Passage
- 12) Drainage arrangement in Tunnels
- 13) Settlement and Building Protection
- 14) Design Specifications for Temporary Works

**OUTLINE DESIGN SPECIFICATIONS  
FOR  
VIADUCT**

## 1 INTRODUCTION

This Design Basis Report pertains to Viaduct Portion of the Delhi Metro Phase-IV project.

### 1.1 SCOPE OF PROJECT

The Viaduct for Delhi Metro Project comprises of simply supported Precast Pre-tensioned twin U-girder (each U-girder supporting one track only)/Post tensioned Segmental Box Girder with RCC sub-structure and bored cast in situ pile /open foundation. The standard gauge of 1435 mm shall be followed. The Centre to Centre distance between two tracks shall be as per approved SoD of DMRC. However, PSC I-Girder / Balanced Cantilever / Steel Composite Girders have been proposed at sharp curves / special spans /crossover/ turnout / railway crossing / highway crossing.

#### 1.1.1 Scope of Design Basis Report (DBR)

This Design Basis Report is intended to fully satisfy the statutory requirements of Indian Railways for design of proposed elevated Viaduct of DMRC Phase-IV. This design basis report covers design basis with design parameters and assumptions to be adopted in design of foundations & substructures and superstructure of the Viaduct/Bridge based on Model DBR issued by RDSO.

The design basis report shall be read in conjunction with the Outline Construction Specifications where appropriate.

#### 1.1.2 Site Particular

The project corridor is located in state of Delhi.

- Maximum Temperature 47.8°C (as per Annexure-F of IRC 6:2017)
- Minimum Temperature -0.4°C (as per Annexure-F of IRC 6:2017)
- Rainfall season July-August
- Average Rainfall 800-1000mm
- Seismic Zone IV

#### 1.1.3 Units

The main units used for design shall be: [m], [mm], [t], [KN/m<sup>2</sup>], [MPa], [°C], [rad].

#### 1.1.4 Codes

All relevant codes as listed in DBR shall be of latest revision including all amendments & corrections.

## 2 TRACK GEOMETRY, TRACK STRUCTURE AND ROLLING STOCK'

Track Geometry, Track Structure & Rolling Stock should be as per the approved SOD of DMRC. Summary of Important parameters are given below:

Gauge : Standard Gauge 1435 mm.

Track C/C distance: as per SoD

Rolling stock width: 3200mm.

Maximum Gradient: as per SoD  
 Track: Ballast less  
 Traction Power: 1x25 kV (AC)

### 3 ROADWAY AND RAILWAY CLEARANCES

The viaduct runs along and crosses several existing roadways and existing railways. The following sections outline the general clearance requirements for these crossings.

#### 3.1 CLEARANCES FOR ROAD TRAFFIC

Clearance for road traffic shall be as per clause 104.4.2 of IRC: 5 i.e. 5.50m at 0.250m (0.225m (width of the crash barrier) + 0.025m (clearance between crash barrier and pier shaft)) from pier shaft outer line i.e. at face of crash barrier. In all cases 5.5m clearance shall be kept from road level to soffit level of Metro structure.

Clearance for Railway Traffic should as per Schedule of Dimensions of Indian Railways & for metro crossings as per SOD of DMRC. General Arrangement Drawing of railway crossing shall be approved by the relevant Railway Authority.

#### 3.2 CLEARANCES FOR ROLLING STOCK OF DMRC

Clearances for Rolling Stock should be as per the approved Schedule of Dimensions of DMRC.

### 4 DESIGN LIFE & SERVICEABILITY

The life of main structural systems should be 100 years (as per clause-15.1.3 & 16.1.3 of IRS-CBC & 3.6.5 of IRS steel Bridge code).

### 5 MATERIALS PARAMETERS

#### 5.1 CONCRETE

##### I. Young's Modulus & Modular ratio

##### A. Young's Modulus

Clause-5.2.2.1 of IRS-CBC shall be followed.

Grade of Concrete (N/mm <sup>2</sup> )	Modulus of Elasticity (kN/mm <sup>2</sup> )
M10	18.0
M15	22.0
M20	25.0
M25	26.0
M30	28.0
M35	29.5
M40	31.0
M45	32.5
M50	34.0
M55	35.0
M60	36.0

**B. Modular Ratio:**

Modular Ratio including long term effects such as creep shall be taken as per clause 5.2.6 of IRS-CBC i.e.  $m_1 = 280/f_{ck}$  for tensile reinforcement &  $m_2 = 420/f_{ck}$  for compression reinforcement.

**II. Grade of Concrete & Cover**

Minimum grade of concrete should be as per clause-5.4.4 of IRS-CBC. For exposure condition referred in Clause-5.4.1 of IRS-CBC. The cover should be as per clause 15.9.2 of IRS-CBC.

In case of foundation, cover shall be taken as 75mm for all conditions of exposure.

**III. Cement**

As per Clause 4.1 of IRS-CBC.

The minimum cementitious material content shall be as per clause-5.4.5 & Table-4 (c) of IRS-CBC.

The maximum water-cement ratio shall be as per clause 5.4.3 & Table-4(a) of IRS-CBC. The total chloride content by weight of cement shall be as per Clause 5.4.6 of IRS-CBC.

**IV. Density**

Density of concrete shall be 25 kN/m<sup>3</sup> for PSC and RCC, 23 kN/m<sup>3</sup> for Plain cement concrete and 26 kN/ m<sup>3</sup> for Wet concrete.

**V. Poisson's Ratio**

Poisson's ratio for all grades of concrete shall be 0.15.

**VI. Thermal Expansion Coefficient**

Coefficient of thermal expansion (a) has been considered as  $11.7 \times 10^{-6} \text{ } ^\circ\text{C}$  in accordance with Clause-2.6.2 of IRS-Bridge Rules.

**VII. Time-Dependent Characteristics of Materials**

- i) Long-term losses should be calculated in accordance with Clause-16.8.2 of IRS-CBC.
- ii) The design shall be done according to construction sequence to be adopted in site.

**5.2 PRESTRESSING STEEL FOR TENDONS**

Prestressing steel shall be as per clause 4.6 of IRS-CBC. Characteristic strength of prestressing tendons shall be as per clause 16.2.4.3 of IRS-CBC.

i) **Prestressing Units** (as per Table-2, Class-II of IS 14268)

All Prestressing steel units shall be of 0.6" strands type (Nominal diameter =15.2mm, Area=140 mm<sup>2</sup>).

ii) **Breaking Strength & Breaking Stress** (as per Table-1, Class-II of IS 14268)

Breaking strength of strand = 260.7 kN

0.2% Proof Load = 234.6 kN

0.1% proof Load (85% of UTS) = 221.6 kN

Minimum breaking stress = 1860 MPa

iii) **Density:** =78.5 kN/m<sup>3</sup>

### 5.2.1 Young's Modulus

Young's modulus of Prestressing steel shall be taken as 195.0GPa as per § 4.6.2.1 of IRS - CBC 1997 for the Strands conforming to IS: 14268.

### 5.2.2 Prestressing

Jacking Force shall be as per Clause- 16.8.1 of IRS-CBC.

Other Parameters:

Sheathing: Corrugated HDPE Duct shall be used as per clause-7.2.6.4.2 of IRS-CBC.

Diameter of Sheathing 107mm ID for 19K15 , 86mm ID for 12K15 and 69mm for 7K15 as per clause 6.2.1 of Technical specifications. Wobble / Curvature shall be 0.0020 /m & 0.170 as per clause Table 26A of IRS-CBC.

Clear Cover shall be provided from outer diameter of duct. Minimum center to center spacing between ducts shall be taken w.r.t outer diameter of duct.

Maximum Slip at anchorage = 6mm (to be decided based on pre-stressing anchorage system adopted).

## 5.3 REINFORCEMENT STEEL (REBARS)

High strength deformed (HYSD) reinforcement bars of Fe-500D grade (TMT), conforming to IS 1786 and Clause 4.5 & 7.1.5 of IRS-CBC shall be used.

I. Young's Modulus:  $E = 200,000$  Mpa

II. Yield Stress:  $f_y = 500$  MPa.

III. Density: 78.5 kN/m<sup>3</sup>

## 5.4 STRUCTURAL STEEL (FOR COMPOSITE BRIDGES & OTHER STRUCTURES IF ANY)

### I. Introduction

Structural steel shall be used for special composite bridges and for miscellaneous use such as railing, supporting utilities, coverings etc.

### II. Structural Steel for Miscellaneous Use

The design of miscellaneous structure shall be done as per IS: 800 and related provisions.

Hollow steel sections for structural use shall be as per IS: 4923.

Steel tubes for structural purpose shall be as per IS: 1161.

Steel for General Structural Purposes shall be as per IS: 2062.

### III. Structural Steel for Composite Bridges

#### A. General

Structural steel conforming to IS: 2062 shall be adopted.

Fabrication shall be done as per provisions of IRS B1 (Fabrication Code).

Design of steel structures shall be done as per IRS steel Bridge Code.

IRC Code: 22 shall be referred for steel-RCC composite construction.

Welding shall be done following IRS Steel Bridge Code, IRS welded Bridge code or relevant IS codes for welding.

Grade#	Tensile Strength (Mpa)	Yield Stress (Mpa)		
		t<20	t=20-40	t>40
E250 B0	410	250	240	230
E350 B0	490	350	330	320
E450 B0	570	450	430	420

\*t-thickness

B. Young's Modulus shall be taken as 21,100kg/mm<sup>2</sup> as per Clause-A-1.3 of IRS-Steel Bridge Code.

C. Density: 7850 kg/m<sup>3</sup> as per clause 505.2.2.1 of IRC: 24.

D. Poisson's Ratio: 0.30 as per clause 505.2.2.1 of IRC: 24.

E. Thermal Expansion Coefficient: 12x10<sup>-6</sup> as per clause 505.2.2.1 of IRC: 24.

## 5.5 DESIGN GROUND WATER TABLE

The Ground water table (Base value) shall be considered as maximum (in terms of RL) of Ground water table data published by (a) Central Ground water board (CGWB), (b) Ground water table reported in Geotechnical report provided by DMRC in tender documents, (c) Ground water table reported in Geotechnical report provided by Design & Build contractor.

The design Ground water table shall be taken as 2.0m higher than the Base value for evaluation of effects for design purposes.

## 5.6 LIQUEFACTION

Liquefaction shall be considered as per IS 1893-Part-1. The design Ground water table shall be used for liquefaction potential calculation. The Moment Magnitude  $M_w$  to be taken in design shall be 7.0. The factor of safety shall be more than 1.0 to ascertain that the strata is not liquefiable.

## 5.7 SOIL PARAMETERS

The values of soil strength parameters ( $c$ ,  $\phi$  etc.) to be used for design purposes shall be lesser of the following:

- 1) As per soil investigation report in the tender document.
- 2) As per soil investigation done by contractor.

The soil investigation report of Bore hole done by contractor shall be compared by soil investigation report of the nearest Bore hole given in the tender document.

## 6 LOADS TO BE CONSIDERED FOR DESIGN

Following are the various loads to be taken into consideration for analysis and design of structures as prescribed in IRS-Bridge Rules up to latest up-to-date correction slip.

### 6.1 DEAD LOAD

Dead load shall be based on the actual cross section area and unit weights of materials and shall include the weight of the materials that are structural components of viaduct and permanent in nature.

#### 6.1.1 SUPER IMPOSED DEAD LOAD (SIDL)

Superimposed dead loads include all the weights of materials on the structure that are not structural elements but are permanent. It includes weight of track form plinth/rails/fasteners/ cables/parapet/ hand-rail OHE mast/ cable trough/ Signaling equipment etc. and will be considered in the design as per following assumptions.

S.No.	Element	Unfactored Load
1	Parapet/Railing	*
2	Plinth	3.40 t/m
3	Rail+Pads (All 4)	0.30 t/m
4	Cables	0.07 t/m
5	Cable trays#	0.01 t/m
6	Deck drainage concrete (Avg. thk. 62.5mm)	0.24 t/m
7	Miscl. (OHE Mast, Signalling , etc.)	0.40 t/m
8	Solar Panel (wherever applicable)	30kg/sqm
9	Noise Barrier (wherever applicable)	0.2 t/m

\*Parapet/Railing weight shall be calculated as per actual. The load due to parapet/railing shall be considered as fixed type and load factor applicable for dead load shall be consider for this component. All other SIDL shall be considered as variable.

# in case cable through cell is used; its weight will be 0.74 t/m

## In case of cross-over, actual track weight including plinths shall be considered for design.

## 6.2 SHRINKAGE & CREEP

Shrinkage and Creep effects will be calculated as per Clause 5.2.3 & 5.2.4 of IRS CBC.

## 6.3 PRE-STRESS FORCE (PR)

The pre-stressing force calculation will be as per Clause-16.8 of IRS-CBC. The loss of pre-stress due to friction will be calculated as per Clause-16.8.3 of IRS-CBC.

For calculation of long-term effects, the relative humidity to be considered as per Annexure A.7 of IRC 112 shall be  $(70(\text{max}) + 47(\text{min}))/2 = 58.5\%$

## 6.4 LIVE LOAD (LL)

### 6.4.1 Railway Vehicular Load

Each component of the structure shall be designed / checked for all possible combinations of these loads and forces. They shall resist the effect of the worst combination:

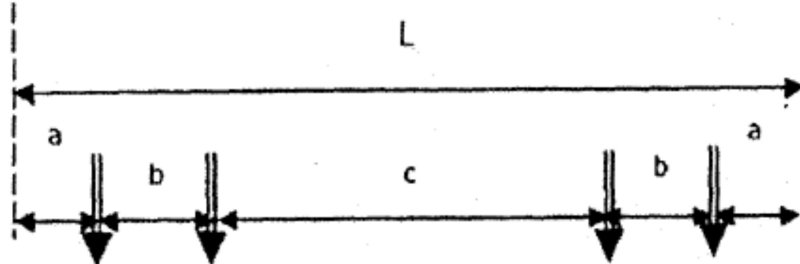

**All axle loads = 17 tons**

Maximum number of successive cars=6

Where,

$L = 22.340\text{m}$  (Length of a car)

$a = 1.920\text{m}$  (overhang)

$b = 2.500\text{m}$  (Wheel base in a bogie)

$c = 13.500\text{m}$  (Distance between Axle-2 and Axle-3 in the car)

Moving load analysis shall be carried out in order to estimate the maximum longitudinal force, max shear and max BM. The simply supported structures shall be designed for Medium Metro Loading Envelopes as tabulated in Annexure-I of Model DBR of RDSO.

In case of Twin U-Girder, each U-Girder will support only one track.

These superstructures and sub-structures will be checked for one track loaded condition as well as both tracks loaded condition (Single Span as well as Both Spans loaded condition).

However, for any other configuration (Axle load, and Axle spacing) of Modern Rolling stock including maintenance, machinery, crane etc., shall be within the loading envelope of present live load configuration.

#### **6.4.2 Dynamic Augmentation**

CDA will be considered as specified in clause 2.4.1.1 of IRS Bridge Rule. No reduction for double track loading will be considered.

#### **6.4.3 Footpath Live Load**

Footpath live load shall be taken as 490 kg/sqm. as per clause 2.3.2 of IRS Bridge Rules. As footpath live load is to be considered with carriageway live load without impact, this design will not be critical for any design except the parapet. The parapet will be designed for this loading.

#### **6.4.4 Longitudinal Force**

Braking load is taken as 18% of the unfactored Axle load.

Traction load is taken as 20% of the unfactored Axle load.

Since both the tracks are supported by a single girder, hence tractive force of one track and braking force of another track will be taken in the same direction to produce worst condition of loading.

As per Clause-2.8.5 of IRS-Bridge Rules, in transverse / longitudinal seismic condition, only 50% of gross tractive effort/braking force will be considered.

Dispersion, of longitudinal forces is not allowed as per Clause-2.8.3.4 of IRS Bridge Rules.

#### **6.4.5 Centrifugal Forces Due to Curvature of Superstructure**

The horizontal centrifugal force due to moving load in curved superstructure is to be considered as per § 2.5 of IRS: BR.

$$C = \frac{W v^2}{127 R}$$

Where W is Live load reaction & C is Centrifugal force (unit of C & W shall be same), v is maximum design speed in km/h and R is radius of curvature in m. This force is assumed to act at a height of 1.830 m above rail top level on safer side.

Design Speed of Live load of 95 km/h will be considered for computation of centrifugal force for curvature up to 450m radius. For sharper curves, speed restrictions as per SOD shall be followed.

#### **6.4.6 Racking Force**

The horizontal transverse loading due to racking specified in IRS-Bridge Rules Clause-2.9 is applicable to design of lateral bracing.

## 6.5 TEMPERATURE EFFECTS

### 6.5.1 A) Overall Temperature (OT)

The loads shall be considered as per Clause-2.6 of IRS-Bridge Rules and Clause-215 of IRC: 6. Temperature variation of  $\pm 35^\circ\text{C}$  will be considered details of which are given below

Maximum Temperature considered as per Annex. F of IRC 6:2017:  $+47.8^\circ\text{C}$

Minimum Temperature considered as per Annex. F of IRC 6:2017:  $-0.4^\circ\text{C}$

Temperature variation as per clause 215.2 of IRC 6 will be  $=(47.8-(-0.4))/2+10=\pm 34.1^\circ\text{C}$  **say  $35^\circ\text{C}$ .**

### B) Differential Temperature (DT)

The provision given in § 215.4 of IRC 6 – 2017, shall be considered to compute effect of differential temperature gradient in absence of any provisions in IRS code. The differential gradient of temperature along depth of superstructure has been reproduced below for ready reference. Short term modulus of elasticity as per Table given under clause 5.1 of DBR shall be used to calculate the effects.

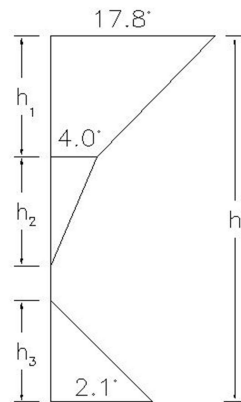

#### Positive Temperature Difference

$$h_1 = 0.3h < 0.15\text{m}$$

$$h_2 = 0.3h > 0.1\text{m} \\ < 0.25\text{m}$$

$$h_3 = 0.3h < 0.15\text{m}$$

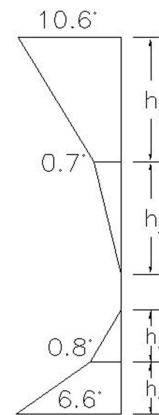

#### Negative Temperature Difference

$$h_1 = h_4 = 0.2h < 0.25\text{m}$$

$$h_2 = h_3 = 0.25h < 0.25\text{m}$$

*Note: For purpose of these calculations no reduction shall be made for presence of track plinths.*

### Temperature Difference for Concrete Bridge Decks

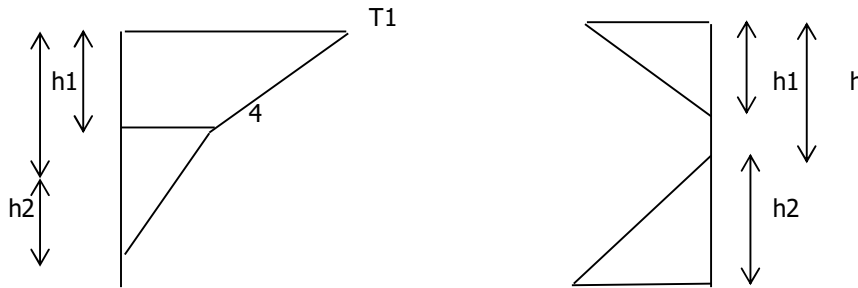
**Positive Temperature Difference**

$$h1 = 0.6h$$

$$h2 = 0.4h$$

H(m)	T1°C
0.2	18
0.3	20.5

**Negative Temperature Difference**

H(m)	T1°C
0.2	4.4

**Temperature Difference across Steel and Composite Sections**

*Note: For purpose of these calculations no reduction shall be made for presence of track plinths.*

**6.5.2 Resistance to Movement of Elastomeric Bearings (BS)**

Elastomeric bearing will resist movement/deformation of superstructure other than applied load i.e. due to variation of temperature/creep strain/shrinkage strain etc. The bearing resistance shall be calculated as per Clause-211.5.1.3 of IRC: 6.

The bearing resistance will produce lateral force on the substructure and foundation. The bearing resistance shall be calculated as  $(V_L \cdot \delta_L - V_R \cdot \delta_R)$ , where  $V_L$  and  $V_R$  are the shear rating of the left and right elastomeric bearings respectively and  $\delta_L$  and  $\delta_R$  are the deck movement at elastomeric bearing location. The above force will be zero when both side spans & supporting bearings are identical, in such case 10% of  $V_L \cdot \delta_L$  shall be considered for design of substructure and foundation

**6.5.3 Rail Structure Interaction (LWR Forces)**

Guidelines vide BS Report No. 119 "RDSO Guidelines for carrying out Rail-Structure Interaction studies on Metro System (version-2)" shall be followed.

A rail structure interaction [RSI] analysis is required because the continuously welded running rails are continuous over the deck expansion joints. The interaction occurs because the rails are directly connected to the decks by fastening system.

1. Rail structure interaction studies shall be done as per provisions of "RDSO Guidelines for carrying out Rail-Structure Interaction studies on Metro System (version-2)". The following shall be adhered to:

- a) Track resistance in loaded and unloaded conditions shall be obtained from cl. 3.2.6 Track Stiffness of "RDSO Guidelines for carrying out Rail-Structure Interaction studies on Metro System (version-2)". As per the clause, the recommended values for track stiffness for ballasted tracks are 60kN/m and 20kN/m for loaded and unloaded track

respectively and recommended values of track stiffness for ballast less tracks are 60kN/m and 40kN/m for loaded and unloaded tracks respectively. The elastic limit is 2 mm for ballasted tracks and 0.5 mm for ballast less tracks. No change in track stiffness is permitted on account of actual track behavior.

- b) The temperature variations, to be used for analysis, shall be taken as per provisions of cl. 3.2.8 Temperature Variations of "RDSO Guidelines for carrying out Rail-Structure Interaction studies on Metro System (version-2)". The following shall be used for analysis:

-The temperature of the bridge does not deviate from the reference temperature by more than  $\pm 35^{\circ}\text{C}$

-The temperature of the rail does not deviate by more than  $\pm 50^{\circ}\text{C}$ .

-The difference in temperature between deck and track does not exceed  $\pm 20^{\circ}\text{C}$ .

-The reference temperature is the temperature of the deck and the rail when the rail is fixed.

- c) Maximum additional stresses in rail in tension as well as compression on account of rail-structure interaction shall be within the permissible limits as prescribed in cl. 3.3.1 Additional Stresses in Rails of "RDSO Guidelines for carrying out Rail-Structure Interaction studies on Metro System (version-2)". The limit prescribed in the document shall be used as it is and no benefit on account of lesser axle load of actual rolling stock shall be permitted.
- d) The provisions of cl. 3.3.2 Displacements of Bridge Elements of "RDSO Guidelines for carrying out Rail-Structure Interaction studies on Metro System (version-2)" shall be adhered to.
- e) Checks must be performed for break in rail continuity due to unusual conditions such as fractures or for maintenance purposes. The provisions of cl. 4.8 "Rail Gap Analysis of RDSO Guidelines for carrying out Rail-Structure Interaction studies on Metro System (version-2)" shall be followed.
- f) Minimum (unfactored) LWR force of 1.6t/m of span length shall be considered for design irrespective of number of tracks.

2. Software and general methodology to be used for carrying out Rail Structure interaction analysis must be validated before adopting the same. A well-established document such as UIC 774-3R may be used for validation.

3. Representative stretches must be chosen for carrying out Rail-Structure interaction which shall include special spans. The same shall be got approved from the engineer.

4. LWR forces shall be considered in appropriate load combinations as specified in cl. 7.0 Load Combinations (Ground IIIb) of the DBR.

## **6.6 WIND LOAD (WL)**

The wind load shall be calculated as per § 2.11 of IRS: BR and IS: 875 (Part 3).

As per § 5.3 of IS: 875 (Part 3)

Design Wind Speed,  $V_z = V_b \cdot k_1 \cdot k_2 \cdot k_3 \cdot k_4$

Where

$V_b$  = Basic wind speed = 50 m/s for Delhi Zone (as per National Building code).

$k_1$  = 1.07 for class IV type structure (§ table 1 of IS: 875 (Part 3)).

$k_2$  = 1.07 for category 2 (§ table 2 of IS: 875 (Part 3)) for 20m Height.

$k_2$  = 1.12 for category 2 (§ table 2 of IS: 875 (Part 3)) for 30m Height

$k_3$  = 1.0 (§ 6.3.3.1 of IS: 875 (Part 3)).

$k_4$  = 1.0 (for non-cyclonic zone as per clause 6.3.4)

However, a bridge shall not be considered to be carrying any live load when the wind pressure at deck level exceeds  $150\text{kg/m}^2$  as per clause 2.11.2 of IRS Bridge rule, however as it is a long viaduct therefore there is fair possibility that once wind pressure exceeds  $150\text{kg/m}^2$  train may be standing static over viaduct due to close of operation therefore in case of wind pressure above  $150\text{kg/m}^2$ , train will be considered as static load i.e. no longitudinal loads or impact loads.

Wind load on train in transverse direction will be calculated based on exposed surface & intensity as per above given values & reference. These are computed for length of train as seen in elevation normal to longitudinal axis. The transverse load will be applied to train at center of projected area of the vehicle.

As per clause 209.3.4 of IRC: 6 the longitudinal wind load on Superstructure will be considered as 25% of Transverse load for Beam/Box/ Plate girder bridges. In case of Truss Bridges longitudinal load on Superstructure will be considered as 50%.

As per clause 209.3.6 of IRC: 6 the longitudinal wind load on Live Load will be considered as 25% of Transverse Wind load considered on Live load.

In case of Pier & Pier cap full load will be considered.

The longitudinal load will be acted simultaneously with transverse load.

## **6.7 SEISMIC FORCE (EQ)**

The purpose of this section is to summarize the methodology and the assumptions that shall be used for the seismic analysis.

### **6.7.1 Seismic Design**

Seismic design philosophy as stated in "Indian Railway Standard code for Earthquake resistant design of Railway Bridges 2017" has been considered. The peak ground acceleration denoted as zone factor is taken as 0.24 since Delhi is situated in zone IV of seismic map of India.

### **6.7.2 Definition of Seismic Input**

Response spectrum ( $S_a/g$  vs  $T$ ) as prescribed in IRS Seismic code 2017, shall be used for seismic load computation.

### 6.7.3 Horizontal Seismic Coefficient

The horizontal seismic design coefficient shall be calculated as per following expression

$$A_h = (Z/2) * (I/R) * (S_a/g)$$

Where,

- A<sub>h</sub> = horizontal seismic coefficient to be considered in design  
 Z = peak ground acceleration or zone factor = 0.24  
 I = importance factor = 1.5  
 R = response modification factor as per Table 3  
 S<sub>a</sub>/g = normalized pseudo spectral acceleration for corresponding to relevant damping of load resisting elements (pier/columns) depending upon the fundamental period of vibration T  
 Damping factor = 5% for reinforced concrete piers.

### 6.7.4 Response Reduction Factor

Response Reduction Factor "R" as per IRS Seismic code 2017 Table -3 shall be as given below

S.No.	Elements	Response Reduction Factor "R"
1	RCC Pier with ductile detailing	3.0
2	PSC Pier/Pier cap/Portal beam	2.0
3	Portal Pier with ductile detailing (Beam integral with pier)	3.0-In Longitudinal direction 4.0-In transverse direction
4	Bearing	2.0
5	Stopper	1.0
6	Foundations	2.0

Note: In addition to the response reduction factor given above, reinforcement detailing of Piers/Portal Piers shall conform to ductility requirements as per Annexure-B of Indian Railway Standard code for Earthquake resistant design of Railway Bridges 2017.

### 6.7.5 Vertical Seismic Coefficient

The seismic zone factor & time period (of Vertical motion) for calculating vertical seismic coefficient shall be considered as per clause 7.3.2 & 9.4.2 of IRS seismic code. The Zone factor for calculating the vertical seismic coefficient will be 2/3\*Zone factor i.e. 2/3\*0.24=0.16.

### 6.7.6 Computation of Fundamental period of vibration

The fundamental time period shall be calculated by any rational method of analysis. Each pier is considered as a single degree of freedom oscillator with mass placed at the Centre of Gravity (COG) of the deck.

The time period can also be calculated based on expression given in Clause 8.1 of Seismic Code 2017, which is as follows:

$$T = 2\pi \sqrt{\delta/g}$$

Where,

$\delta$  = horizontal displacement at top of pier due to horizontal force.

#### a) Mass

- Permanent masses (Self Weights, SIDL) of:
  - (a) Full span longitudinally, which can be resisted by reaction blocks or POT/Spherical bearings during earthquake, at one side of the pier or half of spans on either side of pier in case seismic is resisted by bearings (For longitudinal seismic)
  - (b) Half of spans on either side of pier (For transverse seismic)
- Mass of the pier cap
- 80% mass of the pier
- The earth quake acceleration will be considered on full mass and not buoyant mass.

It may be noted that while calculating lateral seismic forces, 50% live load is included in the seismic weight for transverse direction i.e. Minimum live load among 4 cases i.e. OSOT (one span one track), OSBT (One span both tracks), BSOT (Both span one track) & BSBT (Both span both tracks) will be considered, whereas no live load is included for seismic weight in longitudinal direction.

As per clause 2.8.5 of IRS: Bridge Rule, in transverse/ longitudinal seismic condition, only 50% of gross tractive effort / braking force/centrifugal force/racking force shall be considered.

#### b) Stiffness

- Stiffness shall be calculated with the concrete instantaneous modulus of elasticity, for all structural elements.
- Pier stiffness considering fixed base and free at deck location  $K = 3EI_{eff}/L^3$
- $I_{eff}=0.75I_g$ , as per clause 5.2.1 of IRC: SP: 114-2018. In the calculation of fundamental time period, effective moment of inertia is considered.
- Flexibility of foundation soil system may be considered while calculating time period i.e. foundation and soil spring may be modelled while calculating time period.

The static stiffness of soil spring shall be calculated as per Table-3 of Annexure-C of IS 2911 Part-1 (Section 2). While calculating the static soil stiffness, soil shall be considered as dry granular soil (for time period calculation) with uniform N values of 25 throughout the depth for all cases. In liquefaction zone no soil spring shall be considered.

Only for calculating the time period, dynamic stiffness ( $K_{dynamic}$ ) shall be used and it shall be taken as 3.5 times the static stiffness ( $K_{static}$ ) i.e  $K_{dynamic} = 3.5 * K_{static}$ .

For calculating seismic forces and its effects the static value of soil springs as per clause 12.4.2 of the DBR shall be used.

- Time period of more than 4s shall not be allowed in any case; section needs to be resized when it exceeds 4s.

### 6.7.7 Direction Combinations

The seismic forces shall be assumed to come from any horizontal direction. For this purpose, two separate analyses shall be performed for design seismic forces acting along two orthogonal horizontal directions. The design seismic force resultant (that is axial force, bending moment, shear force and torsion) at any cross section of a bridge component resulting from the analysis in the two orthogonal horizontal directions shall be combined according to the expressions given below.

- a)  $\pm EL_x \pm 0.3 EL_y$
- b)  $\pm 0.3 EL_x \pm EL_y$

Where

$EL_x$  = Force resultant due to full seismic force along X direction, and

$EL_y$  = Force resultant due to full seismic force along Y direction

When vertical seismic forces are also considered, the design seismic force resultants at any cross-section of a bridge component shall be combined as below:

- a)  $\pm EL_x \pm 0.3 EL_y \pm 0.3 EL_z$
- b)  $\pm 0.3 EL_x \pm EL_y \pm 0.3 EL_z$
- c)  $\pm 0.3 EL_x \pm 0.3 EL_y \pm EL_z$

Where  $EL_x$  and  $EL_y$  are as defined above and  $EL_z$  is the force resultant due to full seismic force along vertical direction.

As an alternative to the procedure given above, the forces due to the combined effect of two or three components can be obtained on the basic square root of sum of square (SRSS)

$$\sqrt{(EL_x^2 + EL_y^2)} \quad \text{or} \quad \sqrt{(EL_x^2 + EL_y^2 + EL_z^2)}$$

### 6.8 ERECTION TEMPORARY LOADS (ETL)

Erection forces and effects shall be considered as per Clause-2.13 of IRS-Bridge Rules.

The weight of all permanent and temporary materials together with all other forces and effects which can operate on any part of structure during erection shall be considered in design. The loads arising from most onerous conditions of the construction methods adopted is awaited from the Contractor.

Special care shall be taken that no damage is caused by the construction contractor to the permanent structure. In case of any hole etc., drilled in permanent structural element, the same will be made good by using non-shrink, expansive, high strength grout and its strength shall be better than the structural element and will have to be demonstrated.

### 6.9 DERAILMENT LOADS (DR)

For vertical considerations, check shall be made in accordance with the IRS-Bridge Rules, Appendix-XXV with standard gauge in place of Broad gauge. For ULS and stability check, loading shall be proportional as per maximum axle load.. This derailment load corresponds to an ULS load for SLS combinations (Group-V of IRS-CBC) a 1/1.75 coefficient will be applied to the derailment load. The Sacramento criteria need to be considered for U-Girder.

### **6.10 FORCES ON PARAPET**

The parapets shall be designed to resist lateral horizontal force & a vertical force of 1.50 kN/m applied simultaneously at the top of the parapet as per Clause 2.10 of IRS Bridge Rules.

### **6.11 DIFFERENTIAL SETTLEMENT (DS)**

Differential Settlement between two adjacent viaduct piers shall be as follows.

- i) 12mm for Long Term Settlement;
- ii) 6 mm for Short Term Settlement

The allowable settlement for pile group is 25mm (as per IS 2911-part 4); hence differential settlement between two foundations is considered as half of 25 mm i.e. 12 mm as long-term settlement. The short-term settlement of 6mm is considered to cater for bearing replacement condition.

Differential settlement shall be considered only in the design of continuous structures, if any.

### **6.12 BUOYANCY LOADS**

The design of the foundation shall be done considering design ground water table as referred in clause 5.5 of the DBR.

In case of river bridges, stability check and calculation of base pressure, full buoyancy shall be considered on submerged portion of substructure and foundation up to HFL or LWL as the case may be, irrespective of the type of soil on which the foundation will rest.

Hydro dynamic forces will be considered as per clause 6 of IRS Seismic code.

### **6.13 WATER CURRENT FORCES**

Water current force in submerged portion of substructures and foundations shall be calculated as per Clause 5.9 of IRS Bridge Substructure & Foundation Code

### **6.14 VEHICLE COLLISION LOAD (VCL)**

The vehicle collision load on piers: as per Clause-222 of IRC: 6.

Rules specifying the loads for design of superstructure and sub-structure of bridges and for assessment of the strength of existing bridges should be done as per IRS: Bridge Rules.

All structure near railway track shall be checked for accidental impact from derailed trains as per clause 2.16.4 of IRC Bridge Rules as per Addendum & Corrigendum Slip No. 48 dated 22.06.2017.

### **6.15 GRADIENT EFFECT**

The bearing shall be sandwiched between two true horizontal surfaces. Steel Wedge shall be provided to cater longitudinal slope of superstructure.

## 6.16 BUFFER LOAD

Provision of Buffers is contemplated at the end of temporary terminal stations during stage opening of the Corridors, at Pocket track ends and at the terminal stations of the corridors (at the end of turn back/stabling lines). Such buffers will be of friction type. These buffers will be designed to have stopping performance based on mass of fully loaded train and its deceleration to avoid damage to the train or buffer. Viaduct elements need to be designed for such Buffer load. The exact Buffer loads need to be interfaced and ascertained during the detailed design.

## 6.17 VIBRATION EFFECT

Effect of vibration due to movement of train on Viaduct structure will be taken into consideration. This will be checked in dynamic analysis.

## 7 LOAD COMBINATIONS

7.1 **Methodology:** Provisions of IRS-CBC shall be followed. The partial load factors and load combinations shall be as per Clause-11 and Table-12 of IRS-CBC as modified and shown below:

Load	Abbreviations
Dead load	DL
Super imposed dead load	SIDL
Prestressing	PS
Live Load	LL
Live load on footpath	LFP
Longitudinal force ( Traction & Braking)	LF
Centrifugal force	CF
Over all temperature	OT
Differential Temperature	DT
Long welded rail force	LWR
Racking Forces	RF
Wind forces	WL
Earthquake	EQ
Differential settlement	DS
Derailment	DR
Erection load	ER

Limit state	Loads	Symbol	G I	G II (EQ)		G II (WL)		G III (a)	G III (b)	G V
				G IIa (EQ)	G II b (EQ)	G IIa (WL)	G II b (WL)	Temperature	LWR	
SLS Combinations	Dead Loads	DL	1.00	1.00	1.00	1.00	1.00	1.00	1.00	1.00
	Prestressing	PS	1.00	1.00	1.00	1.00	1.00	1.00	1.00	1.00
	Super Imposed Loads (fixed)	SIDL-1	1.00	1.00	1.00	1.00	1.00	1.00	1.00	1.00
	Super Imposed Loads (variable)	SIDL-2	1.20	1.20	1.20	1.20	1.20	1.20	1.20	1.20
	Earthquake	EQ		1.00	1.00					
	Overall T	OT						1.00	1.00	
	LWR								1.00	
	Differential DT	DT						0.80	0.80	
	Differential settlement	DS	1.00							
	Live load	LL	1.10		0.50		1.00	1.00	0.50	
	Live load on footpath	LWP	1.00		0.50		1.00	1.00	0.50/ 1.00 (##)	
	Derailment Loads	DR								1.00(**)
	Wind Load						1.00	1.00		
ULS Combinations	Dead Loads	DL	1.25	1.25	1.25	1.25	1.25	1.25	1.25	1.25
	Prestressing	PS	1.15/0.87 <sup>(*)</sup>	1.40	1.40	1.15/0.87 <sup>(*)</sup>	1.15/0.87 <sup>(*)</sup>	1.15/0.87 <sup>(*)</sup>	1.15/0.87 <sup>(*)</sup>	1.15/0.87 <sup>(*)</sup>
	Super Imposed Loads (fixed)	SIDL-1	1.25	1.25	1.25	1.25	1.25	1.25	1.25	1.25
	Super Imposed Loads (variable)	SIDL-2	2.00	2.00	2.00	2.00	2.00	2.00	2.00	2.00
	Earthquake	EQ		2.00#	2.00#					
	Overall T	OT						1.50	1.50	
	LWR								1.50	
	Differential DT	DT						1.15	1.15	
	Differential settlement	DS								
	Live load	LL	1.75		0.50		1.40	1.40	0.70	
	Live load on footpath	LWP	1.50		0.50		1.25	1.25	0.6125	
	Derailment Loads	DR								1.00
	Wind Load						1.60	1.25		

In each of SLS and ULS cases, 5 basic load combination groups shall be considered, according to the IRS- CBC.

(\*) 1.15/0.87: In accordance with IRS CBC article 11.3.3., when the Prestressing PR increases the section capacity vs. shear then PR is multiplied by 0.87. When the Prestressing PR decreases the section capacity vs. shear then PR is multiplied by 1.15.

(\*\*) Refer clause 6.9.

#The calculation for seismic force will be done considering  $Z/2$ , however as MCE is proposed to be used only in ULS case as per IRS seismic code, the load factor is modified to 2.0. This is done for ease of calculation.

## 0.50 for two or more tracks and 1.0 for single track.

Notes:

- 1) ULS-Ultimate Limit state.
  - 2) SLS-Serviceability Limit state
  - 3) Wind load and earth quake loads shall not be assumed to be acting simultaneously.
  - 4) Live load shall also include dynamic effect, force due to curvature exerted on tracks, longitudinal forces, braking forces and forces on parapet.
  - 5) Crack width check shall be done in SLS case for combination G I only.
- 7.2 The Superstructure/bearing, sub-structure and foundation will be checked for one track loaded condition as well both track loaded condition, for single span and both spans loaded conditions, as the case may be.
- 7.3 Design of viaduct shall be done in accordance with the construction methodology/ construction sequence to be adopted during execution.
- 7.4 The analysis and design will be carried out for all possible cases of rolling train loads. All the supporting structures, such as superstructure, bearings, substructure and foundations shall be checked for the most onerous cases.

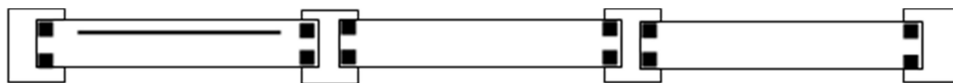

**LL1:** used for Deck Torsion, Bearing Compression, Uplift, Shaft check, Foundation check

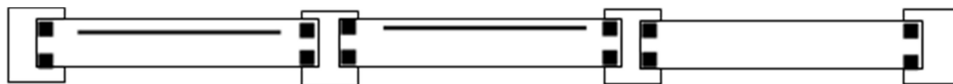

**LL2:** LL2 used for Shaft check, Foundation check

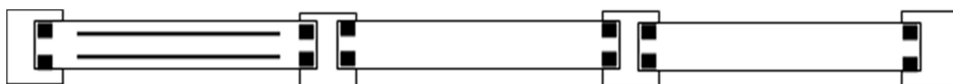

**LL3:** used for Deck check, Bearing Compression check, Shaft check, Foundation check;

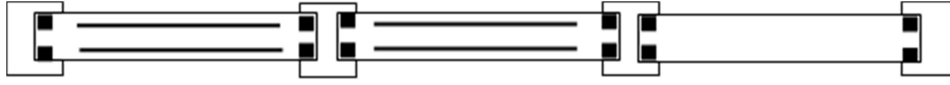

**LL4:** used for shaft check, Foundation check, Shear Key check

## 8 DESIGN CHECK FOR CONCRETE STRUCTURE

### 8.1 ALLOWABLE STRESSES FOR CONCRETE AT SERVICEABILITY LIMIT STATE (SLS)

The stresses at transfer and construction stage during service for prestressed cast in situ and segmental construction shall be as per Clause-16.4.2.2 (Concrete Compressive stress Limitations), Clause-16.4.2.3 (Steel stress Limitations), Clause-16.4.2.4 (Cracking), Clause-17.3.3 (Other types of Connections) and Clause-17.4 (Composite Concrete Constructions) of IRS-CBC.

Clause-10.2 (Serviceability Limit States) of IRS-CBC shall be used for RCC construction (Beams, Columns and Slabs).

#### Summary of Permissible Stresses

##### Precast or Cast-In-Situ Post-Tensioned Structures

No	Load Combination	Allowable compressive strength	Reference	Allowable tensile stress*	Reference
<b>At transfer and/or construction stage</b>					
1	DL +*DS + App.PR	0.5 fci but $\leq 0.4$ fck	CI 16.4.2.2(b) of IRS CBC 1997	<b>1 MPa*</b>	CI 16.4.2.4(b) of IRS CBC 1997
2	Group 1+50% EL	0.5 fci but $\leq 0.4$ fck	(CI 16.4.2.2(b) of IRS CBC 1997	<b>1 MPa*</b>	CI 16.4.2.4(b) of IRS CBC 1997
<b>During Service</b>					
3	SLS G I	0.4 fck	(CI 16.4.2.2(a) of IRS CBC 1997	No tension anywhere	CI 16.4.2.4(b) of IRS CBC 1997
4	SLS G II	0.4 fck	(CI 16.4.2.2(a) of IRS CBC 1997	No tension anywhere	CI 16.4.2.4(b) of IRS CBC 1997
5	SLS G III	0.4 fck	(CI 16.4.2.2(a) of IRS CBC 1997	No tension anywhere	

\* In case of Segmental structures no tension is permitted under any stage or any SLS Load combination as clause 17.3.3 of IRS-CBC.

\*\* In case of Uniform compressive stress distribution in PSC structures, permissible stress shall not be more than  $0.3f_{ck}$ .

#### II RCC Structures

Permissible stress in Concrete (triangular compressive stress distribution) -  $0.50f_{ck}$   
 Permissible stress in Concrete (Uniform compressive stress distribution) -  $0.38f_{ck}$

Permissible stress in Steel

- 0.75fy

## **8.2 ULS CHECK FOR PRESTRESSED CAST-IN SITU CONCRETE/COMPOSITE CONSTRUCTION**

Clause-16.4.3 (Ultimate Limit State: Flexure) to Clause 16.4.6 (Longitudinal Shear) of IRS-CBC shall be applicable for cast-in situ Prestressed construction whereas for composite construction Clause-17.4 (Composite Concrete Construction) shall be used.

## **8.3 ULS CHECK FOR RCC STRUCTURE**

Section Capacity check for RC beams (ULS) for the superstructure should be conforming to Clause-15.4 of IRS-CBC. The design of RCC slabs shall conform to Clause 15.5 of IRS-CBC. The design of column should conform to Clause-15.6 of IRS-CBC.

## **9 DESIGN CHECK FOR STEEL/COMPOSITE STRUCTURE**

The design of steel structure shall be done by IRS Steel Bridge Code/IRS-Welded Bridge Code. The design of composite structure shall be done by IRC: 22.

## **10 DURABILITY & CRACK WIDTH**

### **10.1 DURABILITY**

Provision of Clause-5.4 of IRS-CBC shall be followed. The exposure condition of present corridor is Moderate and in case of Nallah crossing the exposure condition may be treated as "Severe".

### **10.2 CRACK WIDTH CHECK**

For SLS Combination, Group - I, crack width in reinforced concrete members shall be calculated as per Clause-15.9.8.2.1 of IRS-CBC.

The allowable crack width should be as per Clause 10.2.1 (a) (CS-1-12/2014) based on the exposure condition defined in Clause 5.4.1 of IRS-CBC and table-10 of IRS-CBC.

For crack control in columns, clause15.6.7 of IRS-CBC will be modified to the extent that actual axial load will be considered to act simultaneously.

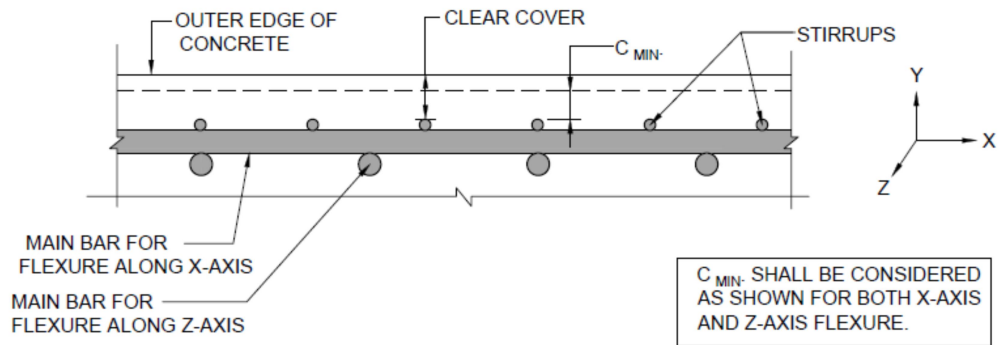
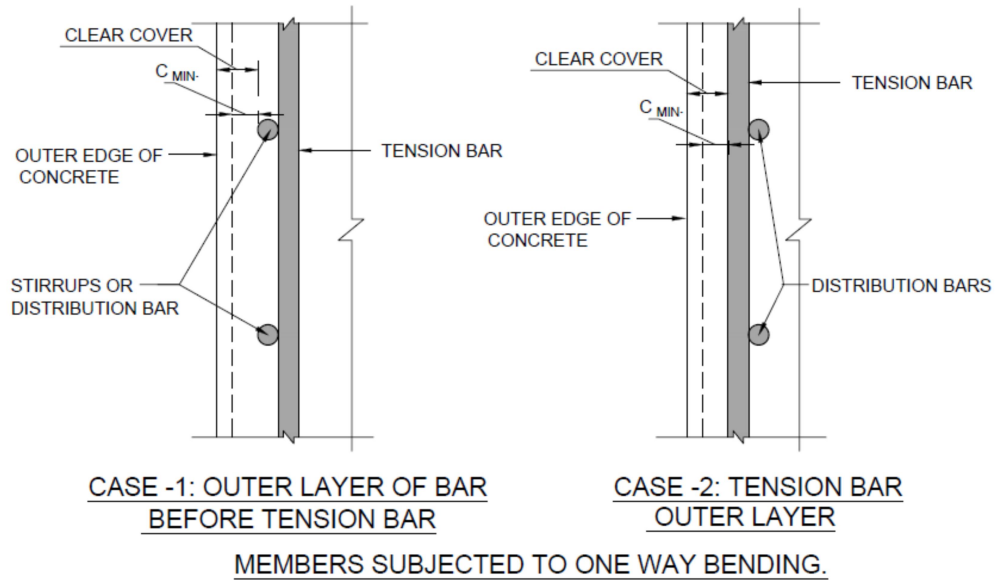

**CLEAR COVER AND  $C_{MIN}$  FOR CRACK WIDTH CALCULATION**

**10.3 DEFLECTION**

The calculation of deflection shall be done in accordance with provisions of UIC-776 3R.

**11 FATIGUE**

**11.1 GENERAL**

Fatigue phenomenon shall be analyzed for those structural elements that are subjected to repetition of significant stress variation (under traffic load). Thus generally the fatigue shall be regarded only for deck structural part supporting the tracks.

## **11.2 PRESTRESSED CONCRETE STRUCTURE**

The fatigue shall be checked as per Clause-13.4 IRS-CBC. However, fatigue check for prestressed concrete structures does not need to be performed as long as the whole section (from top to bottom fiber) remains under compression under SLS load combination 1.

## **11.3 REINFORCED CONCRETE STRUCTURE**

The fatigue shall be checked as per Clause-13.4 of IRS-CBC.

Fatigue check for reinforced concrete structures does not need to be performed unless it is a main structure member (i.e. the deck) supporting the traffic that consists of reinforced concrete. The permissible stress range in unwelded reinforcement as per clause 13.4.1 of IRS CBC shall be 155Mpa up to 16mm diameter & 120Mpa for bars exceeding 16mm diameter.

## **11.4 STEEL/STEEL COMPOSITE STRUCTURES**

Clause-3.6 of IRS-Steel Bridge (up to latest correction slip) / Clause-13.2 of IRS-Welded Bridge code shall govern. If values are required to be used, the train closest to the actual train formation proposed to be run on the DMRC shall be used. Otherwise, detailed counting of cycles shall be done.

## **12 DESIGN METHODOLOGY**

### **12.1 SUPERSTRUCTURE SYSTEM OF VIADUCT**

The Superstructure of the viaduct comprises of simply supported Twin U-Girder.

However sharp curvature/ crossovers / turnouts/ railways crossings / highway crossings, PSC I -Girder/ Balanced Cantilever/Steel Composite girders/Steel Truss may be used. The minimum dimensions shall be considered as per Clause 16.9.6 of IRS-CBC.

Design of superstructure should be done in accordance with construction methodology/ construction sequence to be adopted during execution by DMRC.

#### **Drainage**

The drainage of deck shall be designed to cater the maximum envisaged rainfall intensity and suitable longitudinal and transverse slope should be provided. Moreover the provisions of Clauses-10.4.1.1 & 15.2.2 of IRS-CBC shall be followed.

#### **Solid Pier**

The drain pipe of double wall HDPE corrugated pipes with water collection box at top, shall be located within solid pier to avoid unpleasant aesthetics.

#### **Deck**

The top of soffit slab will be profiled so as to collect the run-off water at multiple points by providing a cross slope of 2.5%. Drainage pipes will be provided to collect the run-off.

## 12.2 BEARING SYSTEM AND ITS DESIGN METHODOLOGY

### a) Bearing System

Considering the span configuration and safety aspects of the structural system (in normal and seismic condition), it is proposed to adopt elastomeric bearings placed underneath the Twin U-Girder for transfer of vertical forces and in-plane forces. The elastomeric bearings shall not be designed for seismic forces and seismic forces will be transferred to substructure via shear key.

POT -PTFE bearing shall be designed as per IRC: 83 Part-III & Spherical bearing shall be designed as per IRC: 83 part-IV.

The elastomeric bearing shall be designed in accordance with EN 1337 part 1 and part 3 wherever required.

### b) Replaceability of Bearings

While finalizing the proposed bearing system, it shall be kept in mind that accessibility and replacement of each part of bearing are of paramount importance as the design life of bearings is shorter than that of the structure. Keeping in view the above cited criteria, all the bearings and pier caps will be detailed for replacement of bearings in the future. The end diaphragms shall be designed to facilitate the operations of jacks during maintenance as per clause 15.9.11.3 of IRS-CBC.

**Special Low Height jacks shall be employed to replace bearings, if minimum vertical clearance is less than 400 mm as stipulated in Clause-15.9.11.4 of IRS-CBC.**

### c) Uplift

If required a holding-down device connecting the deck and the pier head shall be placed in order to prevent the deck from overturning. The holding-down device may be integrated in the pot-bearing system or be a separate system constituted of bars embedded in pier cap and viaduct with appropriate details, permitting translation/rotation. Other systems can also be foreseen.

Due to the lack of appropriate guidelines in Indian codes, the design criteria for holding down device (upward force limit requiring holding down device, design formulas) will be taken from the latest international practice.

## 12.3 SUBSTRUCTURE SYSTEM

### a) Pier Cap

For designing the pier cap as corbel the provisions of Clause-17.2.3 of IRS-CBC should be followed. In case of shear span to effective depth ratio being more than 0.6, pier cap will be designed as flexural member.

Height of pedestal should be in between 150mm and 500mm as per clause 710.10.2 of IRC: 78.

The Pier cap shape shall be suitable at transition pier supporting different types of superstructure instead of providing raised/column pedestal over pier cap.

## b) Piers

The effective length of a cantilever pier for the purpose of slenderness ratio calculation will be taken as per Table-18 of IRS-CBC. In this project most of the columns are isolated columns with elastomeric bearing supporting the superstructure. In either direction the effective length will be taken as  $2.3L_0$  (case 7). Here  $L_0$  represent height of column from top of footing slab/Pile cap to top of pier cap. Effective length of portal column in longitudinal direction will be taken similar to single column i.e.  $2.3L_0$  and for transverse direction it should be taken as  $1.5 L_0$  (case 6).

The design of pier shall be done as per clause 15.6 of IRS CBC.

### Prestressed Cantilever Pier

In case of vertically prestressed piers, minimum longitudinal reinforcement shall be provided as RCC column as per clause 15.9.4.1 of IRS CBC.

Shear reinforcement & ductile detailing shall be done as that of RCC column.

In all SLS combinations, column shall remain in compression.

Clause 16.6.1 of IRS CBC shall be applicable in case of prestressed piers/columns.

## 12.4 FOUNDATION SYSTEM

Foundation shall be designed as per IRS Bridge Substructure & Foundation Code, IRS Concrete Bridge Code, IRC-78, Manual on the design and construction of well foundation; IS-2911 should be followed for design of foundations.

### 12.4.1 Pile Foundation

Foundation analysis and design will be based on IRS Code for Substructure & IRC-78. The forces applied by the pier are transferred to the bottom of the pile cap for this purpose. Reactions in pile are calculated using Rivet theory. The various specific assumptions made for the pile and pile cap design are as follows:

- a) Bored-cast-in-situ multiple pile groups will be adopted.
- b) Minimum 1.0m diameter bored cast-in-situ vertical piles in soil/rock have been contemplated for the foundation of piers. Minimum number of pile in each pile cap shall not be less than 4.
- c) Open foundation have been contemplated for the pier location with rocky strata at shallow depth.
- d) For piles and pile caps, load combinations shall be considered as per IRS-CBC, Table-12. The various specific assumptions made for the pile and pile cap design including pile load testing shall be as per IS: 2911, IRC-78 and IRS-Bridge Sub-structure and Foundation Code.
- e) For pile carrying capacity, all SLS Load combinations as per IRS-CBC will be considered.
- f) Increase in vertical load capacity of pile shall be done as per Table-1 of IS 1893-Part-1.

- g) The lateral load capacity of pile shall be evaluated either by using empirical formulae given in IS: 2911 (Part-1/ section-2) or by soil structure interaction analysis using Winkler's spring model by limiting the lateral deflection as 1% of Pile diameter as per Cl. 709.3.5.2 of IRC: 78.
- h) Initial load tests (not on working pile) will be conducted as per IS: 2911 - Part IV. Initial test is proposed to be conducted for a load of 2.5 times as per the safe vertical load based on static formula.
- i) The working load on pile for vertical and horizontal loads shall be verified through routine load tests during construction.
- j) In case of multiple pile system, spacing between the piles shall not be less than 3 times the diameter of pile in soil and 2.5 times the diameter when founded on rock.
- k) In general the top of pile cap shall be kept about min 500mm below the existing ground level and weight of the earth cover will be applied on top of pile cap when unfavorable. The earth cover on pile cap for any favorable effect (stability, soil horizontal capacity.) will be neglected.
- l) The following limiting values shall not be exceeded for computation of safe load:
- Result of sub-structure investigation will be used for adopting the value of angle of internal friction " $\phi$ " and cohesion of soil " $c$ " as per clause 5.7 of the DBR .
  - Angle of wall friction  $\delta$  shall be taken as equal to  $\phi$  deg.
  - Co-efficient of earth pressure " $K$ " shall be taken as 1.0.
  - Maximum overburden pressure at bottom of pile for calculation of shaft resistance and bearing resistance shall be limited to 15 times the diameter of the pile. The maximum depth shall be considered from existing ground level.
  - For calculating the pile capacities, the design ground water table as per clause 5.5 of the DBR shall be considered.
  - Bulk density corresponding to 100% saturation shall be calculated and used for working out submerged density of soil.
- m) While finalizing length of pile, Clause 705.4.1 of IRC: 78 shall also be followed.
- n) Live load surcharge needs to be considered for pile group which is outside median and where live load is moving over pile cap. Normal Pile groups below median or where there is no live load over pile cap need not to be design for live load surcharge.
- o) In case of foundations near railway crossing effect of railway live load surcharge shall be considered if applicable

### Structural Design

- a) Pile design shall be done according to § 15.6 of IRS CBC 1997. However, for crack control in piles, § 15.6.7 of IRS CBC 1997 it will be clarified that actual axial load will be considered to act simultaneously.
- b) Where there is a risk of liquefaction, the lateral soil resistance of the liquefied layer will be taken as zero.
- c) Pile cap shall be designed based on § 15.8.3.1 of IRS –CBC 1997. No support from soil below pile cap shall be considered.

- d) The thickness of the pile cap shall be kept minimum 1.5 times diameter of the piles for multiple-pile group as per IRC 78.
- e) The structural design of the pile cap shall be carried out as per §10.2.2 & §15.4 and §15.8.3 of IRS CBC. Crack width shall be checked for load combination 1 as per §15.9.8.2 IRS CBC.

#### **12.4.2 Soil Structure Analysis**

When designing element forces or estimating displacements the soil stiffness and other parameters shall be assessed based on clause 5.7 of the DBR considering the design ground water table as per clause 5.5 of the DBR.

#### **12.4.3 Well Foundation & Open foundation**

Well Foundation & Open foundation shall be designed as per IRS Bridge Substructure & Foundation Code/ IRC: 78.

### **13 LIST OF DESIGN CODES AND STANDARDS, APPLICABILITY**

The IRS Codes shall be followed in principle. Although main clauses have been mentioned in the DBR, the other relevant clauses as available in the IRS codes shall also be followed, whenever applicable. If provisions are not available in IRS, the order of preference shall be as follows, unless specified otherwise:

#### **For railway loading related issues:**

- i. UIC Codes
- ii. Euro Codes
- iii. Any other code, which covers railway loading.

#### **For other Design/ detailing related issues:**

- i. IS
- ii. IRC
- iii. EURO
- iv. AASHTO
- v. Any international code with approval of DMRC.

#### **13.1 IRS CODES (WITH LATEST VERSIONS, ALL AMMENDMENTS AND CORRECTION SLIPS UP TO DATE OF BIDDING)**

- IRS Bridge Rules
- IRS Concrete Bridge Code
- IRS Bridge substructure & Foundation Code
- IRS Steel Bridge Code
- IRS Fabrication Code (B1)
- IRS Welded Bridge Code
- IRS code for Earthquake resistant design of Railway Bridges 2017

### 13.2 IRC CODES (WITH LATEST VERSIONS AND ALL AMMENDMENTS UP TO DATE OF BIDDING)

- IRC: 5 Standard Specification & Code of Practice for Road Bridges - General Features of Designs
- IRC:6 Standard Specification & Code of Practice for Road Bridges- Loads and Stresses
- IRC: 18 Design Criteria for Pre-stressed Concrete Road Bridges (post Tensioned Concrete)
- IRC: 22 Specification & Code of Practice for Road Bridges, Section VI - Composite Construction for Road Bridges
- IRC: 24 Standard Specification & Code of Practices for Road Bridges, Section V- Steel Road Bridges
- IRC: 78 Standard Specification & Code of Practice for Road Bridges - Section Foundations & Sub-Structure
- IRC: 83(I) Standard Specification & Code of Practice for Road Bridges, Part-I Metallic Bearings
- IRC: 83(II) Standard Specification & Code of Practice for Road Bridges, Part-II Elastomeric Bearings
- IRC: 83 (III) Standard Specification & Code of Practice for Road Bridges, Part-III POT, POT-cum PT;TE, Pin and Metallic Guide Bearings
- IRC: 83 (IV) Standard Specification & Code of Practice for Road Bridges, Part, IV Spherical and Cylindrical Bearings.
- IRC: 112 Code of practice for Concrete Bridges
- IRC-SP-71 Guidelines for Design and Construction of Pre-cast Pre-tensioned Girders for bridges

### 13.3 IS CODES (WITH LATEST VERSIONS AND ALL AMMENDMENTS UP TO DATE OF BIDDING)

- IS: 269 Specs for Ordinary and Low Head Portland cement
- IS: 383 Specs for coarse and fine aggregates from natural sources for concrete
- IS: 432 Specs for Mild steel and medium tensile steel bars (Part 1)
- ID: 456 Plain and reinforced concrete - code of practice
- IS: 800 Code of practice for General Construction Steel
- IS: 875 Code of Practice for Design Loads Part 1, 2 3, 4& 5 (Other than Earthquake)
- IS: 1080 Design and construction of shallow foundations in soils (other than raft ring and shell)
- IS: 1343 Code of practice for Pre-stressed concrete-based essentially on CP-110
- IS: 1364 Hexagon Head Bolts, Screws & nuts of product grades A & B Part 1 (part 1 Hexagon, Head Bolts (size range M 16 to M64)

- IS: 13920 Ductile detailing of reinforced concrete structures subjected to seismic forces code of practice
- IS: 1489 Specification for Portland pozzolana cement (Fly ash based)
- IS: 1786 High strength deformed steel bars and wires for concrete reinforcement
- IS: 1893 Criteria for Earthquake Resistant Design of structures
- IS: 1904 Design and construction of foundations in soils: general requirements.
- IS: 1905 Code of practice for structural use of unreinforced masonry.
- IS: 2062 Specifications for weldable Structural steel
- IS: 2502 Code of Practice for Bending and Fixing of Bars for Concrete Reinforcement
- IS: 2911 Code of practice for Design and construction of Pile foundation Part 1 (Part I/Sec 1) Concrete Piers Section 2 Board Cast-in-situ-piles (with amendments)
- IS 2911 Code of Practice for Design & construction of Pile foundations Part 4 Load test on piles
- IS: 2950 Design and construction of raft foundations
- IS: 3935 Code of Practice for Composite Construction
- IS: 4326 Code of practice for Earthquake resistant design and construction of Buildings
- IS: 4923 Hollow steel sections for structural use -specification
- IS: 8009 Calculation of settlements of shallow foundations
- IS: 8112 Specifications for 43 grade ordinary Portland cement
- IS: 9103 Specifications of Concrete admixtures
- IS: 11384 Code of practice for Composite Construction in Structural Steel and Concrete
- IS: 12070 Code of practice for Design and construction of shallow foundation on Rocks
- IS: 12269 Specification for 53 grade ordinary Portland cement
- IS: 14268 Uncoated Stress Relieved Low relaxation Seven-ply Strands for Prestressed concrete
- IS: 14593 Design and Construction of Bored Cast-in-Situ Piles Founded on Rocks.

#### **13.4 BS CODES (WITH LATEST VERSIONS AND ALL AMMENDMENTS UP TO DATE OF BIDDING)**

- BS: 4447 Specifications for the performance of prestressing anchorage for post-tensioned concrete.
- BS: 4486 Specifications for high tensile bars used for prestressing.
- BS: 5400 Code of Practice for Design of Concrete Bridges Part 4-1990.

- BS: 8006 Code of Practice for strengthened reinforced soils and other fills-1995.
- BS: 8007 Design of Concrete structures for retaining liquids.

### **13.5 OTHERS (WITH LATEST VERSIONS AND ALL AMMENDMENTS UP TO DATE OF BIDDING)**

- UIC:776-1R Loads to consider in Railway Bridge Design
- UIC:776-3R Deformation of Bridges
- UIC: 772 Then International Union Railway Publication
- UIC: 774 - 3R Rail structure interaction
- CEB\_FIB Model Code 1990 for Concrete Structures
- The design relating to Fire safety and escape shall be in accordance with the requirements of NFPA 130 standard for fixed guide way system.
- FIP Recommendations for the Acceptance of Post-tensioned systems.
- M.O.R.T and Highways specifications.
- Euro code 0 Basis of Structural Design.
- Euro code I Actions on Structures-Part 2-Traffic Loads on Bridges.
- Euro code 2 Design of Concrete Structures- Part 1.1: General Rules and Rules for Building.
- Euro code 2 Design of Concrete Structures- Part 2, Concrete Bridges - Design and Detailing Rules.
- ACI 358: IR-92 (American Concrete Institute) for assessment of dynamic impact for transit Guide ways.
- ROSO Guidelines for carrying out RSI (Version 2.0) issued in January 2015 BS-111 version-3 issued in January 2015.

All codes listed above shall be of latest revision including all amendments & corrections.

## **14 DESIGN SOFTWARE**

Any commercial or proprietary software can be used for analysis/design provided the same is validated with manual computations or other standard software in multiple scenarios.

**OUTLINE DESIGN SPECIFICATIONS  
FOR  
ELEVATED STATIONS**

## 1. INTRODUCTION

### 1.1 BRIEF DESCRIPTION OF THE PROJECT

This Design basis report is applicable for elevated metro stations of Delhi Metro Rail Project of DMRC-Phase-IV.

### 1.2 SCOPE OF DBR

The object of this Design Basis Document is to establish a common procedure for the design of "Elevated Metro Stations of DMRC phase-IV". This is meant to serve as a guide to the designer but compliance with the rules there-in does not relieve them in any way of their responsibility for the stability and soundness of the structure designed. The design of Elevated Metro Stations requires an extensive and thorough knowledge and entrusted to only to specially qualified engineers with adequate practical experience in structure designs.

Design basis report (DBR) of viaduct shall be followed for following structures/elements of station:

- For single pier station.
- Structural elements which support metro live loads.

This design basis report is applicable for following structures/structural elements:

- Structural elements of station which do not support metro live loads.
- Ancillary structures

Prestressed concrete structures shall be designed as per IS: 1343. RCC Structures shall be designed by IS: 456. Steel structure design shall be designed by IS: 800. Seismic design shall generally be governed by IS: 1893.

The design basis report shall be read in conjunction with the Outline Construction Specifications where appropriate.

### 1.3 SITE PARTICULAR

The project corridor is located in state of Delhi & NCR

- Maximum Temperature : 47.8°C (as per Annexure-F of IRC 6:2017)
- Minimum Temperature : -0.4°C (as per Annexure-F of IRC 6:2017)
- Rainfall season : July-August

- Average Rainfall : 800-1000mm
- Seismic Zone : IV

## 1.4 UNITS

The main units used for design will be: [m], [mm], [t], [kN], [kN/m<sup>2</sup>], [MPa], [°C], [rad].

## 1.5 CODES

All relevant codes as listed in DBR shall be of latest revision including all amendments & corrections.

## 2. DESIGN SPECIFICATION

### 2.1 MATERIALS

#### 2.1.1 Cement

For plain and reinforced concrete structures cement shall be used as per clause 5.1 of IS: 456. For PSC structures Cl. 5.1 of IS: 1343 shall be used.

#### 2.1.2 Concrete

As per Cl. 6, 7, 8, 9 and 10 of IS: 456 in case of Plain and Reinforced Concrete structures and Clause 6, 7, 8,9 and 10 of IS: 1343 for Pre-stressed concrete structures.

Short term modulus of elasticity ( $E_c$ ) shall be taken as per Cl. 6.2.3.1 of IS: 456 for Plain and Reinforced Concrete structures and IS: 1343 for Pre-stressed concrete structures. The modular ratio for concrete grades shall be taken as per Annex B of IS: 456.

#### 2.1.3 Prestressing steel for tendons

As per Cl. 5.6.1 of IS: 1343.

##### 2.1.3.1 Young's Modulus

As per Cl. 5.6 of IS: 1343.

##### 2.1.3.2 Prestressing Units

As per Cl. 13 of IS: 1343.

##### 2.1.3.3 Maximum initial Prestress

As per Cl. 19.5.1 of IS: 1343.

### 2.1.3.4 Sheathing

As per Cl. 12.2 of IS: 1343.

### 2.1.4 Density

- 25 kN/m<sup>3</sup> for Reinforced concrete & Prestressed concrete
- 24 kN/m<sup>3</sup> for Plain concrete
- 26 kN/m<sup>3</sup> for wet concrete

For density of strands and all other materials, the densities shall be considered as per IS Codes.

### 2.1.5 Structural Steel

Structural steel used shall conform to following:

- a) Hollow steel sections as per IS: 4923
- b) Steel for general Structural Purpose as per IS: 2062
- c) Steel tubes for structural purpose as per IS: 1161

#### NOTE:

- I. Grade of steel to be used shall be indicated, shall not be less than minimum grade as applicable, based on whether structure is taking moving loads or not and relevant code as indicated in (II) and (III) below.
- II. Design of steel structure will be governed by IS 800. In case of composite (steel-concrete) structure it will be governed by IS: 11384 & IS: 3935.
- III. Fabrication shall be done in accordance with IS: 800.

Tensile Strength / Yield Strength

Structural steel conforming to IS: 2062 shall be adopted.

Welding shall be done as relevant IS codes for welding.

Grade#	Tensile Strength (Mpa)	Yield Stress (Mpa)		
		t<20	t=20-40	t>40
E250 B0	410	250	240	230
E350 B0	490	350	330	320
E450 B0	570	450	430	420

Where,  $t$  = thickness of steel members

- Young's Modulus shall be taken as  $20,000\text{kg/mm}^2$  as per Clause 2.2.4 of IS: 800
- Density:  $7850\text{ kg/m}^3$  as per clause 2.2.4 of IS: 800
- Poisson's Ratio: 0.30 as per clause 2.2.4 of IS: 800
- Thermal Expansion Coefficient:  $12 \times 10^{-6}$  as per clause 2.2.4 of IS: 800

### 2.1.6 Reinforcement Steel (Rebars)

As per Cl. 5.6 of IS: 456 for Plain and Reinforced concrete structures and as per Cl. 5.6.2 of IS: 1343 for prestressed concrete structures.

Note: HYSD steel bars having minimum elongation of 14.5% and conforming to requirements of IS : 1786 shall be used.

#### 2.1.6.1 Reinforcement Detailing

All reinforcement shall be detailed in accordance with Cl. 12 & 26 of IS: 456 & SP: 34 for plain and reinforced concrete structures and as per Cl. 12.3 & 19.6.3 of IS: 1343 for PSC structures.

The ductile detailing of seismic resisting RC elements shall comply with ductile requirements of IS: 13920.

## 2.2 DURABILITY

Durability of concrete shall be as per Cl. 8 of IS: 456 for Plain & RCC, as per Cl. 8 of IS: 1343 for PSC elements and as per IS: 800 for steel structures.

For foundation & pier design, the exposure condition is Moderate. And in case of Nallah crossing, the exposure condition may be treated as "Severe".

### 2.2.1 Concrete Grades

The minimum grade of concrete shall be as per IS: 456 for Plain and RCC structures and IS: 1343 for PSC structures.

### 2.2.2 Cover to Reinforcement

As per Cl. 26.4 of IS: 456 for Plain and RCC structures and Cl. 12.3.2 of IS: 1343 for PSC structures. Cover to Prestressing steel shall be in accordance with Cl. 12.1.6 of IS: 1343.

For the Pile foundations, cover shall be taken as 75mm for all exposure conditions.

### 2.2.3 Fire Resistance Period

All the structural elements shall be designed for minimum period of fire resistant of 2 hour. The minimum element thickness for fire resistance shall be as per Cl. 21 of IS: 456 for concrete structures and as per IS: 800 for steel structures.

### 2.2.4 Crack width Check

All structural concrete elements shall be designed to prevent excessive cracking due to flexure, early age thermal and shrinkage. Flexural crack width shall be checked in accordance with Cl. 35.3.2 and 43 of IS: 456 for Plain and RCC structures and Cl. 20.3.2 & 24.2 of IS: 1343 for PSC structures.

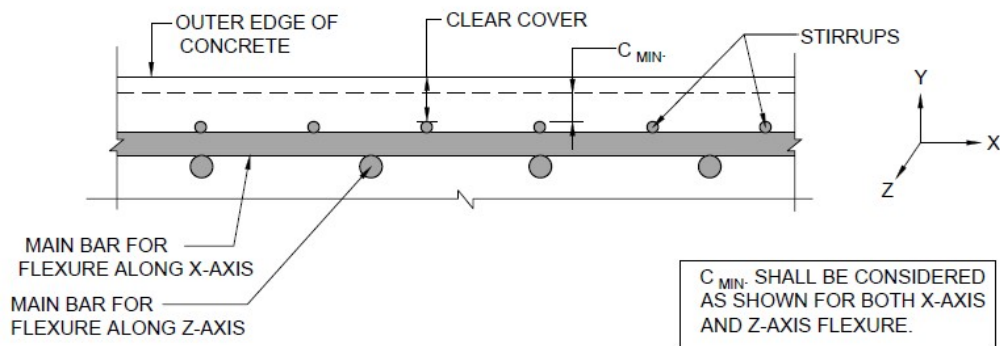
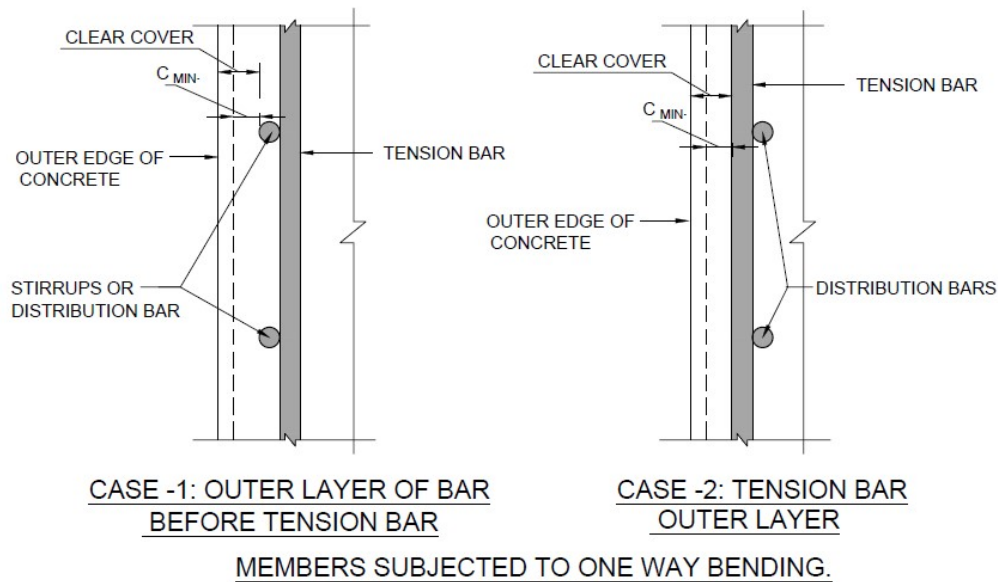

## 2.3 CLEARANCES

- Wherever the station locations are proposed on road or off-road, clearances for road traffic shall be minimum 5.5m beyond the outer face of pier i.e. in all cases 5.5 m clearance shall be kept from road level to soffit level of any structures.
- Clearance for Railway traffic shall be as per SOD of DMRC Phase-IV.
- Vertical & Horizontal clearances for rolling stock are as follows and shall be as per the approved SOD of DMRC Phase-IV.

### 2.3.1 Vertical Clearance

- The minimum plinth thickness is assumed as 195 mm
- The distance between top of rail and top of the plinth is assumed as 219 mm
- Top of rail to top of finished platform level is taken as 1090 mm.

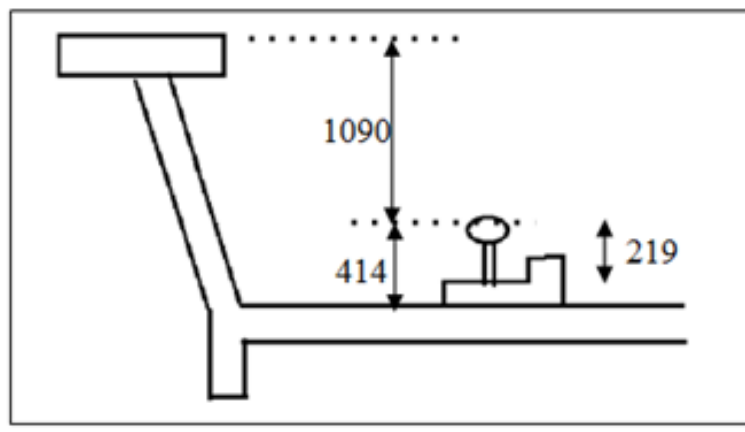

### 2.3.2 Horizontal Clearance

Gauge length and Distance between platform edge and C/L of track shall be as per SOD of DMRC phase-IV.

## 2.4 DESIGN GROUND WATER TABLE

The Ground water table (Base value) shall be considered as maximum (in terms of RL) of Ground water table data published by (a) Central Ground water board (CGWB), (b) Ground water table reported in Geotechnical report provided by DMRC in tender documents, (c) Ground water table reported in Geotechnical report provided by Design & Build contractor.

The design Ground water table shall be taken as 2.0m higher than the Base value for evaluation of effects for design purposes.

## 2.5 LIQUEFACTION

Liquefaction shall be considered as per IS 1893-Part-1. The design Ground water table shall be used for liquefaction potential calculation. The Moment Magnitude  $M_w$  to be taken in design shall be 7.0. The factor of safety shall be more than 1.0 to ascertain that the strata are not liquefiable.

## 2.6 SOIL PARAMETERS

The values of soil strength parameters ( $c$ ,  $\phi$ , etc.) to be used for design purposes shall be lesser of the following:

- i) As per soil investigation report in the tender document.
- ii) As per soil investigation done by contractor.

The soil investigation report of Bore hole done by contractor shall be compared by soil investigation report of the nearest Bore hole given in the tender document.

## 2.7 DESIGN LOAD

### 2.7.1 Dead Load (DL)

Dead load shall be based on the actual cross sectional area and unit weights of materials and shall include the weight of structural members of the station building.

### 2.7.2 Super Imposed Dead Load For Non Track Area (SIDL)

#### FIXED SIDL (SIDL)

**For platform slabs, the following loads in SIDL will be taken**

- Floor finishes is assumed to be a  $3.6 \text{ kN/m}^2$  uniform load as per architectural requirement.
- Suspension load is assumed to be  $2.0 \text{ kN/m}^2$  uniform load (Suspension load will be considered as the load of false ceiling and services. This load will be considered where ever is applicable.
- Light partition wall load is assumed to be  $1.0 \text{ kN/m}^2$  uniform load.

**For concourse area, the following loads in SIDL will be considered.**

- Floor finishes is assumed to be a  $3.6 \text{ kN/m}^2$  uniform load as per architectural requirement.

- Load due to additional fill in the toilets (brick bat) shall be considered as per architectural drawing.
- Suspension load is assumed to be 2.0 kN/m<sup>2</sup> uniform load (Suspension load will be considered as the load of false ceiling and services. This load will be considered where ever is applicable.
- Loads due to escalator / lift will be considered as per manufacturer's detail.
- Light partition wall load should be taken as minimum 1.0 kN/m<sup>2</sup> at concourse.
- Loads due to Platform screen door (PSD) shall be considered as per actual.
- Loads due to solar panel shall be considered as 30 kg/m<sup>2</sup>.
- SIDL for Technical Room shall be as follows:
  - i) UPS Room\* : 25\*\* kN/m<sup>2</sup>
  - ii) ASS room\* : 15\*\* kN/m<sup>2</sup>
  - iii) Other Technical Room\* : 10\*\* kN/m<sup>2</sup>

\*This should be verified with actual load and its location.

\*\* Values are minimum load to be considered in design. Actual loads will be calculated on the basis of equipment & machinery which have to be installed at detail design stage. The concentrated load of 40kN for ASS/UPS room and 20kN for other technical room shall also be considered in design.

**Note:**

- a) The walls loading will be taken based on actual location shown in architectural drawings. External wall load/glazing load will be taken as per details provided in architectural drawings. It is proposed to take 230 mm thick brick wall with 20 mm thick plaster on either side. However, the same shall not be taken less than 2.4 kN/m<sup>2</sup>.

Above loads intensities are minimum loads to be considered in design, Actual load may be higher as per detailed architectural drawings.

### 2.7.3 Live loads (LL)

Location	Distributed load (kN/m <sup>2</sup> )	Concentrated load (kN)
<b>Public/Staff Room</b>		
Concourse Floor	5	4.5
Staircase area	5	4.5
Platform	5	4.5
Office Accommodation	5	4.5
Shop	5	4.5

Foot over Bridge (FOB)	5	4.5
------------------------	---	-----

#### 2.7.4 Earthquake Loads (EQ)

Earthquake design shall follow the seismic requirement of IS: 1893 (Part1)

Horizontal Seismic Coefficient- The horizontal seismic design coefficient shall be calculated as per following expression

$$A_h = (Z/2) * (I/R) * (S_a/g)$$

Where,

$A_h$  = horizontal seismic coefficient to be considered in design

$Z$  = peak ground acceleration or zone factor = 0.24

$I$  = importance factor = 1.5

$R$  = response modification factor = 5

$S_a/g$  = normalized pseudo spectral acceleration for corresponding to relevant damping of load resisting elements (pier/columns) depending upon the fundamental period of vibration  $T$

Damping factor = 5% for RCC structures

Damping factor = 2% for steel structures

##### 2.7.4.1 Drift Limitations

The storey drift in the building shall satisfy the drift limitation specified in IS: 1893.

##### 2.7.4.2 Seismic detailing

i) For RCC structures as per IS: 13920

ii) For other structures as per IS: 4326

### 2.7.5 Wind Loads (WL)

Wind Loads (longitudinal & transverse) shall be calculated as stated in IS 875: Part 3-2015 (Part-3).

Wind loads will be calculated in accordance with IS 875: Part 3-2015.

$$\text{Design wind speed } V_z = V_b * K_1 * K_2 * K_3 * K_4$$

$$V_b \text{ (basic wind speed)} = 50 \text{ m / sec (As per NBC)}$$

$$K_1 \text{ (risk coefficient)} = 1.07 \text{ (for 100 years mean probable design life), Table 1, pg.-7}$$

$$K_2 = \text{as per table 2, pg-8 based on terrain category and structure height}$$

$$K_3 \text{ (Topography factor)} = 1.0, \text{ as per Cl.6.3.3.1, page-8}$$

$$K_4 = 1.0 \text{ for Non cyclonic zone as per Cl.6.3.4, pg.-8}$$

Based on the above, Design wind pressure at height  $z$ ,  $(P_z) = 0.6 \times V_z \times V_z$  Cl. 7.2, pg.-9

Design wind pressure,  $P_d = P_z * K_d * K_a * K_c$  = wind directionality factor, pg.9 / 10

$K_d$  = wind directionality factor, page 9 / 10 of IS: 875-3-2015 = 0.9 for buildings

$K_a$  = area averaging factor, pg.9/10 = 0.8 Table 4 (for contributory area > 100 m<sup>2</sup>)

$K_c$  = combination factor, pg. 9/10 = 0.9 Cl. 7.3.3.13 of IS: 875-2015, Page 16

### 2.7.6 Construction and Erection Loads (ER)

The weight of all temporary and permanent materials together with all other forces and effects which can operate on any part of structure during erection shall be taken into account. Allowances shall be made in the permanent design for any locked in stresses caused in any member during erection.

### 2.7.7 Temperature Load (TL)

As per Cl. 19.5 of IS: 456. Temperature gradient shall be considered as per CL. 215 of IRC-6, if applicable.

### **2.7.8 Shrinkage**

Shrinkage strain shall be evaluated as Cl. 6.2.4 of IS: 456 for plain and RCC structures and Cl. 6.2.4 of IS: 1343 for prestressed concrete structures.

### **2.7.9 Creep**

Creep strain shall be evaluated as Cl. 6.2.5 of IS: 456 for plain and RCC structures and Cl. 6.2.5 of IS: 1343 for prestressed concrete structures.

#### **2.7.9.1 Earth Pressure (EP) & Water pressure (WP)**

In the design of structures or part of structures below ground level, such as retaining walls and underground pump room/ water tanks etc. the pressure exerted by soil or water or both shall be duly accounted for. When a portion or whole of the soil is below the free water surface, the lateral earth pressure shall be evaluated for weight of soil diminished by buoyancy and the full hydrostatic pressure. (As per IS: 875-part 5).

All foundation slabs / footings subjected to water pressure shall be designed to resist a uniformly distributed uplift equal to the full hydrostatic pressure. Checking of overturning of foundation under submerged condition shall be done considering buoyant weight of foundation.

If any of the structure supporting metro building is subjected to earth pressure, the loads and effects shall be calculated accordance with 5.7 of IRS substructure code.

#### **2.7.10 Surcharge Load (SL)**

In the design of structures or the parts of the structures below ground level, such as retaining walls & underground pump room/ water tank etc. the pressure exerted by surcharge from stationary or moving load, shall be duly accounted for.

#### **2.7.11 Prestressing force (PS)**

The prestressing force should be as per IS: 1343.

#### **2.7.12 Settlement (DS)**

Maximum and differential settlement shall not exceed, as provided in Table 1 of IS: 1904. The allowable settlement for pile group is 25mm (as per IS 2911-part 4);

#### **2.7.13 Other Forces and Effects**

As per Cl. 19.6 of IS: 456.

## 2.8 LOAD COMBINATIONS

Load	Abbreviations
Dead load	DL
Super imposed dead load (Fixed)	SIDL
Prestressing	PS
Live Load	LL
Temperature Load	TL
Wind Load	WL
Earthquake Load	EQ
Differential settlement	DS
Earth Pressure	EP
Water Pressure	WP
Surcharge Load	SL
Erection load	ER

- a) For PSC elements, the load combinations shall be as per table 7 of IS: 1343.
- b) For steel structures, the load combinations shall be as per IS: 800.
- c) For RCC structures / elements, shall be as per Table 18 of IS: 456 and IS: 1893-1 as follows:

**Table 18 Values of Partial Safety Factor  $\gamma_f$  for Loads**  
(Clauses 18.2.3.1, 36.4.1 and B-4.3)

Load Combination	Limit State of Collapse			Limit States of Serviceability		
	<i>DL</i>	<i>IL</i>	<i>WL</i>	<i>DL</i>	<i>IL</i>	<i>WL</i>
(1)	(2)	(3)	(4)	(5)	(6)	(7)
<i>DL + IL</i>	1.5		1.0	1.0	1.0	-
<i>DL + WL</i>	1.5 or	-	1.5	1.0	-	1.0
<i>DL + IL + WL</i>	0.9 <sup>1)</sup>		1.2	1.0	0.8	0.8

### NOTES

- While considering earthquake effects, substitute *EL* for *WL*.
  - For the limit states of serviceability, the values of  $\gamma_f$  given in this table are applicable for short term effects. While assessing the long term effects due to creep the dead load and that part of the live load likely to be permanent may only be considered.
- <sup>1)</sup> This value is to be considered when stability against overturning or stress reversal is critical.

## **2.9 Deflection Criteria**

The deflection limitations as per Cl. 23.2 of IS: 456 for Plain and RCC Structures and Cl. 20.3.1 if IS: 1343 for PSC structures shall be followed.

### **2.9.1 Lateral Sway**

The lateral sway at the top of the building due to wind loads should not exceeds  $H/500$ , where 'H' is the height of the building.

## **2.10 FOUNDATION SYSTEM**

### **2.10.1 Type of foundation:**

Considering the nature of ground, type of proposed structure, expected loads on foundation, the following type of foundations are considered practical:

- a. Spread or pad footing
- b. Raft Foundation
- c. Pile foundation

No matter the type of foundation to be adopted, the following performance criteria shall be satisfied:

1. Foundation must not fail in shear
2. Foundation must not settle by more than the settlements permitted as per table-1 of IS: 1904. The allowable settlement for pile group is 25mm (as per IS 2911-part 4);

### **2.10.2 Design of Pile Foundation**

IS: 2911 shall be followed for design of pile, load capacity etc. Theoretical estimation of settlement for deep foundation shall be done in accordance with IS: 8009-Part-2.

The forces applied by the pier are transferred to the bottom of the pile cap for this purpose. Reactions in pile are calculated using Rivet theory. The various specific assumptions made for the pile and pile cap design are as follows:

- a. Bored-cast-in-situ multiple pile groups will be adopted.
- b. The various specific assumptions made for the pile and pile cap design including pile load testing shall be as per IS: 2911.
- c. Increase in vertical load capacity of pile shall be done as per Table-1 of IS 1893-Part-1.
- d. The lateral load capacity of pile shall be evaluated either by using empirical formulae given in IS: 2911 (Part-1/ section-2) or by soil structure interaction

- analysis using Winkler's spring model by limiting the lateral deflection as 1% of Pile diameter.
- e. Initial load tests (not on working pile) will be conducted as per IS: 2911 - Part IV. Initial test is proposed to be conducted for a load of 2.5 times as per the safe vertical load based on static formula.
  - f. The working load on pile for vertical and horizontal loads shall be verified through routine load tests during construction.
  - g. In case of multiple pile system, spacing between the piles shall not be less than 3 times the diameter of pile in soil and 2.5 times the diameter when founded on rock.
  - h. The following limiting values shall not be exceeded for computation of safe load:
    - Result of sub-structure investigation will be used for adopting the value of angle of internal friction " $\phi$ " and cohesion of soil " $c$ " as per 2.6. of this DBR.
    - Angle of wall friction  $\delta$  shall be taken as equal to  $\phi$  deg.
    - Co-efficient of earth pressure " $K$ " shall be taken as 1.0.
    - Maximum overburden pressure at bottom of pile for calculation of shaft resistance and bearing resistance shall be limited to 15 times the diameter of the pile. The maximum depth shall be considered from existing ground level.
    - For calculating the pile capacities, the design ground water table shall be considered as per Cl. 2.4 of this DBR.
    - Bulk density corresponding to 100% saturation shall be calculated and used for working out submerged density of soil.
  - i. While finalizing length of pile, Clause 705.4.1 of IRC: 78 shall also be followed.
  - j. In general the top of pile cap shall be kept about min 500mm below the existing ground level and weight of the earth cover will be applied on top of pile cap when unfavourable. The earth cover on pile cap for any favourable effect (stability, soil horizontal capacity.) will be neglected.
  - k. Live load surcharge needs to be considered for pile group which is outside median and where live load is moving over pile cap. Normal Pile groups below median or where there is no live load over pile cap need not to be design for live load surcharge.
  - l. In case of foundations near railway crossing effect of railway live load surcharge shall be considered if applicable

### 2.10.3 Open foundation

Open foundation shall be designed as per IS: 456, IS: 1904, IS: 6403. Calculation of settlements shall be done as per IS: 8009-Part-1.

### 2.11 Design of water retaining structures

The underground tank in a station shall be designed as a water retaining structure based on IS: 3370. Various types of loadings shall be considered in the design of the underground tank. The side walls shall be subjected to earth pressure. The water table being high in the area, horizontal pressure due to it shall also be considered. Stability of water tank shall be checked against buoyancy and foundation raft shall be designed for the worst of buoyant force and soil pressure. The tank shall also be designed for surcharge loading if any. Water proofing treatment shall be done on the external surface as well as in the internal surface.

### 2.12 MASONRY WALLS

All Masonry walls shall be treated as non-structural infill panels and shall be treated as one way / two way slab panels spanning between adjoining beams and columns to check structural safety. Masonry walls shall be designed as un-reinforced masonry as per IS: 1905 and IS: 4326. Shear connector reinforcement between walls & upper beams and walls & sides of columns shall be provided for external walls, while the internal partition walls shall be connected with roof slabs/beams using dry packing mortar between top of walls and soffit of slab / beam.

## 3. LIST OF DESIGN CODES AND STANDARDS

The design shall be carried out as per provision of these design specifications. Reference shall be made to the following codes for any additional information:

Order of preferences of codes shall be as follows:

- i. IS
- ii. IRS
- iii. IRC
- iv. BS or Euro Codes
- v. AASHTO
- vi. Any international code with approval of DMRC.

### 3.1 IS CODES (WITH LATEST VERSIONS)

- IS: 269            Specs for Ordinary and Low Head Portland cement
- IS: 383            Specs for coarse and fine aggregates from natural sources for concrete

- IS: 432 Specs for Mild steel and medium tensile steel bars (Part 1)
- ID: 456 Plain and reinforced concrete - code of practice
- IS: 800 Code of practice for General Construction Steel
- IS: 875 Code of Practice for Design Loads Part 1, 2 3, 4& 5 (Other than Earthquake)
- IS: 1080 Design and construction of shallow foundations in soils (other than raft ring and shell)
- IS: 1343 Code of practice for Pre-stressed concrete-based essentially on CP-110
- IS: 1364 Hexagon Head Bolts, Screws & nuts of product grades A & B Part 1 (part 1 Hexagon, Head Bolts (size range M 16 to M64)
- IS: 13920 Ductile detailing of reinforced concrete structures subjected to seismic forces code of practice
- IS: 1489 Specification for Portland pozzolana cement (Fly ash based)
- IS: 1786 High-strength deformed steel bars and wires for concrete reinforcement
- IS: 1893 Criteria for Earthquake Resistant Design of structures
- IS: 1904 Design and construction of foundations in soils: general requirements.
- IS: 1905 Code of practice for structural use of unreinforced masonry.
- IS: 2062 Specifications for weldable Structural steel
- IS: 2502 Code of Practice for Bending and Fixing of Bars for Concrete Reinforcement
- IS: 2911 Code of practice for Design and construction of Pile foundation Part 1  
(Part I/Sec 1) Concrete Piers Section 2 Board Cast-in-situ-piles (with amendments)
- IS 2911 Code of Practice for Design & construction of Pile foundations Part 4 Load test on piles
- IS: 2950 Design and construction of raft foundations
- IS: 3935 Code of Practice for Composite Construction
- IS: 4326 Code of practice for Earthquake resistant design and construction of Buildings

- IS: 4923      Hollow steel sections for structural use -specification
- IS: 8009      Calculation of settlements of shallow foundations
- IS: 8112      Specifications for 43 grade ordinary Portland cement
- IS: 9103      Specifications of Concrete admixtures
- IS: 11384     Code of practice for Composite Construction in Structural Steel and Concrete
- IS: 12070     Code of practice for Design and construction of shallow foundation on Rocks
- IS: 12269     Specification for 53 grade ordinary Portland cement
- IS: 14268     Uncoated Stress Relieved Low relaxation Seven-ply Strands for Prestressed concrete
- IS: 14593     Design and Construction of Bored Cast-in-Situ Piles Founded on Rocks.

### **3.2    IRS CODES (WITH LATEST VERSIONS)**

- IRS Bridge Rule
- IRS Concrete Bridge Code
- IRS Bridge substructure & Foundation Code
- IRS Steel Bridge Code
- IRS Fabrication Code (B1)
- IRS Welded Bridge Code
- IRS code for Earthquake resistant design of Railway Bridges 2017

### **3.3    IRC CODES (With Latest Versions)**

- IRC: 5        Standard Specification & Code of Practice for Road Bridges - General Features of Designs
- IRC:6        Standard Specification & Code of Practice for Road Bridges- Loads and Stresses
- IRC: 18      Design Criteria for Pre-stressed Concrete Road Bridges (post Tensioned Concrete)
- IRC: 22      Specification & Code of Practice for Road Bridges, Section VI - Composite Construction for Road Bridges
- IRC: 24      Standard Specification & Code of Practices for Road Bridges, Section V-Steel Road Bridges

- IRC: 78 Standard Specification & Code of Practice for Road Bridges - Section Foundations & Sub-Structure
- IRC: 83(I) Standard Specification & Code of Practice for Road Bridges, Part-I Metallic Bearings
- IRC: 83(II) Standard Specification & Code of Practice for Road Bridges, Part-II Elastomeric Bearings
- IRC: 83 (III) Standard Specification & Code of Practice for Road Bridges, Part-III POT, POT-cum PT;TE, Pin and Metallic Guide Bearings
- IRC: 83 (IV) Standard Specification & Code of Practice for Road Bridges, Part, IV Spherical and Cylindrical Bearings.
- IRC: 112 Code of practice for Concrete Bridges
- IRC-SP-71 Guidelines for Design and Construction of Pre-cast Pre-tensioned Girders for bridges

#### **3.4 BS CODES (WITH LATEST VERSIONS)**

- BS: 4447 Specifications for the performance of prestressing anchorage for post-tensioned concrete.
- BS: 4486 Specifications for high tensile bars used for prestressing.
- BS: 5400 Code of Practice for Design of Concrete Bridges Part 4-1990.
- BS: 8006 Code of Practice for strengthened reinforced soils and other fills-1995.
- BS: 8007 Design of Concrete structures for retaining liquids.

#### **3.5 OTHERS (WITH LATEST VERSIONS)**

- UIC:776-1R Loads to consider in Railway Bridge Design
- UIC:776-3R Deformation of Bridges
- UIC: 772 Then International Union Railway Publication
- UIC: 774 - 3R Rail structure interaction
- CEB\_FIB Model Code 1990 for Concrete Structures
- The design relating to Fire safety and escape shall be in accordance with the requirements of NFPA 130 standard for fixed guide way system.
- FIP Recommendations for the Acceptance of Post-tensioned systems.
- M.O.R.T and Highways specifications.

- Euro code 0 Basis of Structural Design.
- Euro code 1 Actions on Structure-Part 2-Traffic Loads on Bridge.
- Euro code 2 Design of Concrete Structures- Part 1.1: General Rules and Rules for Building.
- Euro code 2 Design of Concrete Structures- Part 2, Concrete Bridges - Design and Detailing Rules.
- ACI 358: IR-92 (American Concrete Institute) for assessment of dynamic impact for transit Guide ways.
- ROSO Guidelines for carrying out RSI (Version 2.0) issued in January 2015 BS-111 version-3 issued in January 2015.

All codes listed above shall be of latest revision including all amendments & corrections.

#### **4. DESIGN SOFTWARE**

Any commercial or proprietary software can be used for analysis/design provided the same is validated with manual computations or other standard software in multiple scenarios.

**OUTLINE DESIGN SPECIFICATIONS  
FOR  
DOUBLE DECKER STRUCTURE**

# 1 INTRODUCTION

This Design Basis Report pertains to Double Decker Viaduct Portion of the Delhi Metro Phase-IV project.

## 1.1 SCOPE OF PROJECT

The Viaduct for Delhi Metro Project comprises of simply supported Precast Pre-tensioned twin U-girder (each U-girder supporting one track only)/Post tensioned Segmental Box Girder with RCC sub-structure and bored cast in situ pile /open foundation. The standard gauge of 1435 mm shall be followed. The Centre to Centre distance between two tracks shall be as per approved SOD of DMRC. However, PSC I-Girder / Balanced Cantilever / Steel Composite Girders have been proposed at sharp curves / special spans /crossover/ turnout / railway crossing / highway crossing.

PWD has planned to construct an elevated 4/6 lane corridor in the same alignment as the metro. It has since been decided that the PWD elevated corridor and the Metro Viaduct will share a common set of foundations and substructure in order to eliminate the crowded set of piers and foundation. It has also been decided that the construction of the elevated corridor will be carried out by the Metro with cost sharing by PWD.

The metro viaduct runs on the top level and the PWD flyover at the lower level in a double-decker arrangement with both viaducts being supported on common single piers.

This report highlights the general arrangement of the flyover and the combined substructure, design parameters and methodology to be adopted for detailed design of these structures.

Flyover Deck shall be designed as per applicable IRC code whereas the Metro Viaduct will be designed as per IRS codes. The common substructure and foundations for the combined Metro and elevated corridor will be designed by IRS Codes. Additionally, the design of common substructure & foundations shall also be checked as per IRC codes and worst of the two designs shall be adopted.

The general arrangement for flyovers as proposed in this project consists of standard spans of 24 to 27m in most of the length of the flyover. The span arrangement has been decided matching with the spans of the metro viaduct. All the spans are simply supported for the metro and flyover structure. Only deck continuity is to be provided for the flyover structure for a minimum length of 120 to 130m to ensure the smooth ride and less noise in general and specifically in the station zone. The minimum thickness of deck for flyover structure shall be 200mm. Provision of expansion joints shall be made with local thickening of the slab.

The superstructure consists of divided 4-lane/ 6-Lane carriageway with a central median to suite the requirement of the pier size required for the metro viaduct support.

The design basis report shall be read in conjunction with the Outline Construction Specifications where appropriate.

The typical cross section of the double-decker viaduct is shown in the figure below:-

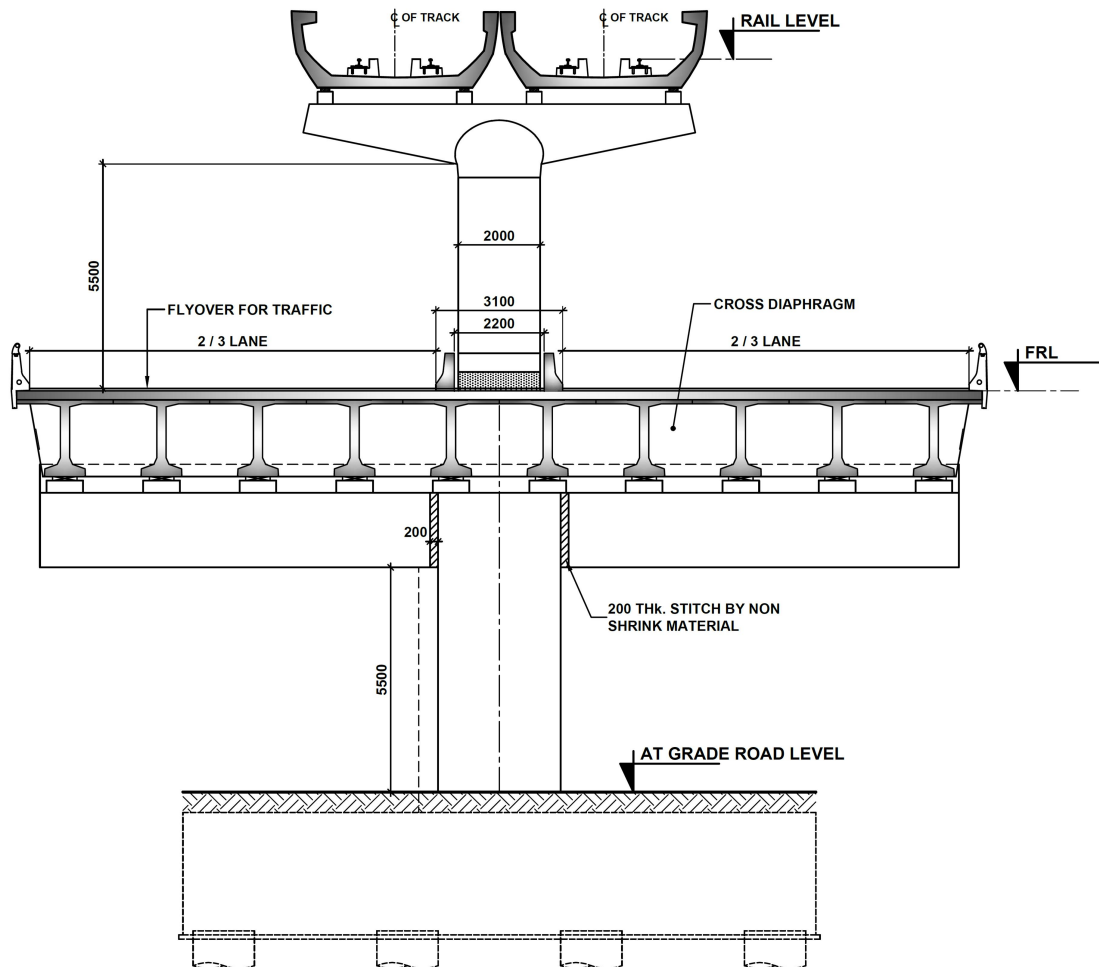

### 1.1.1 Scope of Design Basis Report (DBR)

This Design Basis Report is intended to fully satisfy the statutory requirements of Indian Railways for design of proposed elevated Viaduct of DMRC Phase-IV and all other structures except the deck of the flyover. This design basis report covers design parameters and assumptions to be adopted in design of foundations & substructures and superstructure of the Double decker Viaduct based on Model DBR issued by RDSO. However, in addition to the IRS requirements the piles, pilecaps, piers upto road level, deck supporting road traffic etc shall also have to satisfy the requirements of IRC:112 and other codes related to design of flyovers etc.

### 1.1.2 Site Particular

The project corridor is located in state of Delhi.

- Maximum Temperature      47.8°C (as per Annexure-F of IRC 6:2017)
- Minimum Temperature      -0.4°C (as per Annexure-F of IRC 6:2017)
- Rainfall season              July-August
- Average Rainfall            800-1000mm
- Seismic Zone                 IV

### 1.1.3 Units

The main units used for design shall be: [m], [mm], [t], [kN/m<sup>2</sup>], [MPa], [°C], [rad].

### 1.1.4 Codes

All relevant codes as listed in DBR shall be of latest revision including all amendments & corrections.

## 2 TRACK GEOMETRY, TRACK STRUCTURE AND ROLLING STOCK

Track Geometry, Track Structure & Rolling Stock should be as per the approved SOD of DMRC. Summary of Important parameters are given below:

Gauge : Standard Gauge 1435 mm.

Track C/C distance: as per SoD

Rolling stock width: 3200mm.

Maximum Gradient: as per SoD

Track: Ballast less

Traction Power: 1x25 kV (AC)

## 3 ROADWAY AND RAILWAY CLEARANCES

The viaduct runs along and crosses several existing roadways and existing railways. The following sections outline the general clearance requirements for these crossings.

### 3.1 CLEARANCES FOR ROAD TRAFFIC

Clearance for road traffic shall be as per clause 104.4.2 of IRC: 5 i.e. 5.50m at 0.250m (0.225m (width of the crash barrier) + 0.025m (clearance between crash barrier and pier shaft)) from pier shaft outer line i.e. at face of crash barrier. In all cases 5.5m clearance shall be kept from road level to soffit level of Metro structure.

Clearance for Railway Traffic should as per Schedule of Dimensions of Indian Railways & for metro crossings as per SOD of DMRC. General Arrangement Drawing of railway crossing shall be approved by the relevant Railway Authority.

### 3.2 CLEARANCES FOR ROLLING STOCK OF DMRC

Clearances for Rolling Stock should be as per the approved Schedule of Dimensions of DMRC.

### 3.3 GENERAL FUNCTIONAL REQUIREMENTS

Flyover superstructure consists of deck supporting 4 Lane/ 6 Lane traffic having divided carriageway with median at center. Some of the salient geometrical features are described below:

- Vertical clearance : minimum 5.5m above the road level below for flyover and 5.5m above flyover top below metro viaduct
- Central median : open median of 2.2m clear width, 3.1m with crash barrier
- Crash barrier : RCC crash barrier (0.5m wide) for each carriageway

- Cross slope : cross slope of 2.5% at each carriageway
- Expansion joints : single / double strip seal joints
- Wearing coat : 56mm thick (50mm thick bituminous concrete and 6mm thick water-proofing layer)

### 3.4 CHOICE OF STRUCTURAL SYSTEM

The choice of structural system is done on the basis of following aspects:

**Functionally Effective** – The completed structures should have two separate carriageways of 2 LANE/3LANE TRAFFIC for each direction, divided by a median (3.1m median including crash barrier with 2.0 m clear gap between crash barriers outer edges through which the pier column passes).

**Ease of construction** – pre-cast pre-tensioned girders has been proposed for the flyover superstructure. The substructure is single rectangular/circular pier. The structural system is chosen to make use of the site conditions favoring pre-cast construction to save time. Construction scheme is described in the succeeding section.

**Maintenance** – As the structures fall on a busy road, it is desirable to opt for spherical bearings, thus reducing the maintenance and replacement of bearings to the maximum possible extent. However, choice of bearing type (elastomeric vs spherical) shall depend on design requirements

**Economy** – Structural system and span arrangement are chosen so as to limit the requirement of heavy equipment. Moreover, the system chosen are in line with the metro viaduct superstructure.

### 3.5 CONSTRUCTION METHODOLOGY FOR FLYOVER SUPERSTRUCTURE

- The sequence of construction of the flyover with combined substructure and foundation is described below:
- Bored cast in situ piles are installed up to the pile cut off level as per co-ordinates and levels mentioned in the approved pile layout drawings. The temporary liners if required may be used while boring till the rock level.
- Excavation for pile caps is then carried out at the foundation locations.
- Formwork with reinforcement cage for pile caps are set and concreting for pile cap is done with dowels left for piers.
- Formwork with reinforcement cage for lower pier portion is erected and with suitably designed staging systems and the piers are cast till the soffit of the pier cap for flyover.
- Formwork with reinforcement cage for flyover pier cap is erected and the cap is cast.
- Formwork with reinforcement cage for the upper pier is erected and the piers are cast till the soffit of the pier cap for metro viaduct.
- Formwork with reinforcement cage for flyover pier cap is erected and the cap is cast.
- The Superstructure launching will be done into two stages. The erection/launching scheme for pre-cast girder of metro/flyover superstructure is to be decided by the contractor.

- Construction followed by installation of strip seal expansion joints are then carried out at both ends of the flyover spans.
- Construction of wearing coat over completed flyover is then carried out

#### 4 DESIGN LIFE & SERVICEABILITY

The life of main structural systems should be 100 years (as per clause-15.1.3 & 16.1.3 of IRS-CBC, clause 3.6.5 of IRS steel Bridge code and clause 5.8.1 of IRC-112).

#### 5 MATERIALS PARAMETERS

Material Parameters listed below are from IRS codes and will be applicable for checks being done as per IRS codes. While checking of structures as per IRC Codes, the material properties shall be taken as per IRC Codes.

##### 5.1 CONCRETE

###### I. Young's Modulus & Modular ratio

###### A. Young's Modulus

Clause-5.2.2.1 of IRS-CBC shall be followed.

Grade of Concrete (N/mm <sup>2</sup> )	Modulus of Elasticity (kN/mm <sup>2</sup> )
M10	18.0
M15	22.0
M20	25.0
M25	26.0
M30	28.0
M35	29.5
M40	31.0
M45	32.5
M50	34.0
M55	35.0
M60	36.0

###### B. Modular Ratio:

Modular Ratio including long term effects such as creep shall be taken as per clause 5.2.6 of IRS-CBC i.e.  $m_1 = 280/f_{ck}$  for tensile reinforcement &  $m_2 = 420/f_{ck}$  for compression reinforcement.

###### II. Grade of Concrete & Cover

Minimum grade of concrete should be as per clause-5.4.4 of IRS-CBC. For exposure condition referred in Clause-5.4.1 of IRS-CBC. The cover should be as per clause 15.9.2 of IRS-CBC.

In case of foundation, cover shall be taken as 75mm for all conditions of exposure.

###### III. Cement

As per Clause 4.1 of IRS-CBC.

The minimum cementitious material content shall be as per clause-5.4.5 & Table-4 (c) of IRS-CBC.

The maximum water-cement ratio shall be as per clause 5.4.3 & Table-4(a) of IRS-CBC. The total chloride content by weight of cement shall be as per Clause 5.4.6 of IRS-CBC.

#### IV. Density

Density of concrete shall be 25 kN/m<sup>3</sup> for PSC and RCC, 23 kN/m<sup>3</sup> for Plain cement concrete and 26 kN/ m<sup>3</sup> for Wet concrete.

#### V. Poisson's Ratio

Poisson's ratio for all grades of concrete shall be 0.15.

#### VI. Thermal Expansion Coefficient

Coefficient of thermal expansion (α) has been considered as 11.7 x10<sup>-6</sup> °C in accordance with Clause-2.6.2 of IRS-Bridge Rules.

#### VII. Time-Dependent Characteristics of Materials

- i) Long-term losses should be calculated in accordance with Clause-16.8.2 of IRS-CBC.
- ii) The design shall be done according to construction sequence to be adopted in site.

### 5.2 PRESTRESSING STEEL FOR TENDONS

Prestressing steel shall be as per clause 4.6 of IRS-CBC. Characteristic strength of prestressing tendons shall be as per clause 16.2.4.3 of IRS-CBC.

#### i) Prestressing Units (as per Table-2, Class-II of IS 14268)

All Prestressing steel units shall be of 0.6" strands type (Nominal diameter =15.2mm, Area=140 mm<sup>2</sup>).

#### ii) Breaking Strength & Breaking Stress (as per Table-1, Class-II of IS 14268)

Breaking strength of strand	= 260.7 kN
0.2% Proof Load	= 234.6 kN
0.1% proof Load (85% of UTS)	= 221.6 kN
Minimum breaking stress	= 1860 MPa

#### iii) Density: =78.5 kN/m<sup>3</sup>

#### 5.2.1 Young's Modulus

Young's modulus of Prestressing steel shall be taken as 195.0GPa as per § 4.6.2.1 of IRS -CBC 1997 for the Strands conforming to IS: 14268.

#### 5.2.2 Prestressing

Jacking Force shall be as per Clause- 16.8.1 of IRS-CBC.

Other Parameters:

Sheathing: Corrugated HDPE Duct shall be used as per clause-7.2.6.4.2 of IRS-CBC.

Diameter of Sheathing 107mm ID for 19K15 , 86mm ID for 12K15 and 69mm for 7K15 as per clause 6.2.1 of Technical specifications. Wobble / Curvature shall be 0.0020 /m & 0.170 as per clause Table 26A of IRS-CBC.

Clear Cover shall be provided from outer diameter of duct. Minimum center to center spacing between ducts shall be taken w.r.t outer diameter of duct.

Maximum Slip at anchorage = 6mm (to be decided based on pre-stressing anchorage system adopted).

### 5.3 REINFORCEMENT STEEL (REBARS)

High strength deformed (HYSD) reinforcement bars of Fe-500D grade (TMT), conforming to IS 1786 and Clause 4.5 & 7.1.5 of IRS-CBC shall be used.

- I. Young's Modulus:  $E = 200,000 \text{ Mpa}$
- II. Yield Stress:  $f_y = 500 \text{ MPa}$ .
- III. Density:  $78.5 \text{ kN/m}^3$

### 5.4 STRUCTURAL STEEL (FOR COMPOSITE BRIDGES & OTHER STRUCTURES IF ANY)

#### I. Introduction

Structural steel shall be used for special composite bridges and for miscellaneous use such as railing, supporting utilities, coverings etc.

#### II. Structural Steel for Miscellaneous Use

The design of miscellaneous structure shall be done as per IS: 800 and related provisions.

Hollow steel sections for structural use shall be as per IS: 4923.

Steel tubes for structural purpose shall be as per IS: 1161.

Steel for General Structural Purposes shall be as per IS: 2062.

#### III. Structural Steel for Composite Bridges

##### A. General

Structural steel conforming to IS: 2062 shall be adopted.

Fabrication shall be done as per provisions of IRS B1 (Fabrication Code).

Design of steel structures shall be done as per IRS steel Bridge Code.

IRC Code: 22 shall be referred for steel-RCC composite construction.

Welding shall be done following IRS Steel Bridge Code, IRS welded Bridge code or relevant IS codes for welding.

Grade#	Tensile Strength (Mpa)	Yield Stress (Mpa)		
		t<20	t=20-40	t>40
E250 B0	410	250	240	230
E350 B0	490	350	330	320
E450 B0	570	450	430	420

\*t-thickness

- B. Young's Modulus shall be taken as 21,100kg/mm<sup>2</sup> as per Clause-A-1.3 of IRS-Steel Bridge Code.
- C. Density: 7850 kg/m<sup>3</sup> as per clause 505.2.2.1 of IRC: 24.
- D. Poisson's Ratio: 0.30 as per clause 505.2.2.1 of IRC: 24.
- E. Thermal Expansion Coefficient: 12x10<sup>-6</sup> as per clause 505.2.2.1 of IRC: 24.

## 5.5 DESIGN GROUND WATER TABLE

The Ground water table (Base value) shall be considered as maximum (in terms of RL) of Ground water table data published by

- a) Central Ground water board (CGWB),
- b) Ground water table reported in Geotechnical report provided by DMRC in tender documents,
- c) Ground water table reported in Geotechnical report provided by Design & Build contractor.

The design Ground water table shall be taken as 2.0m higher than the Base value for evaluation of effects for design purposes.

## 5.6 LIQUEFACTION

Liquefaction shall be considered as per IS 1893-Part-1. The design Ground water table shall be used for liquefaction potential calculation. The Moment Magnitude Mw to be taken in design shall be 7.0. The factor of safety shall be more than 1.0 to ascertain that the strata is not liquefiable.

## 5.7 SOIL PARAMETERS

The values of soil strength parameters (c,  $\phi$  etc.) to be used for design purposes shall be lesser of the following:

- 1) As per soil investigation report in the tender document.
- 2) As per soil investigation done by contractor.

The soil investigation report of Bore hole done by contractor shall be compared by soil investigation report of the nearest Bore hole given in the tender document.

## 6 LOADS TO BE CONSIDERED FOR DESIGN

Following are the various loads to be taken into consideration for analysis and design of structures as prescribed in IRS-Bridge Rules up to latest up-to-date correction slip.

## 6.1 DEAD LOAD

Dead load shall be based on the actual cross section area and unit weights of materials and shall include the weight of the materials that are structural components of viaduct and permanent in nature.

### 6.1.1 SUPER IMPOSED DEAD LOAD (SIDL)

Superimposed dead loads include all the weights of materials on the structure that are not structural elements but are permanent. It includes weight of track form plinth/rails/ fasteners/ cables/parapet/ hand-rail OHE mast/ cable trough/ Signaling equipment etc. and will be considered in the design as per following assumptions.

S.No.	Element	Unfactored Load
		(t/m)
1	Parapet/Railing	*
2	Plinth	3.40
3	Rail+Pads (All 4)	0.30
4	Cables	0.07
5	Cable trays#	0.01
6	Deck drainage concrete (Avg. thk. 62.5mm)	0.24
7	Miscl. (OHE Mast, Signalling , etc.)	0.40

\*Parapet/Railing weight shall be calculated as per actual. The load due to parapet/railing shall be considered as fixed type and load factor applicable for dead load shall be consider for this component. All other SIDL shall be considered as variable.

# in case cable through cell is used; its weight will be 0.74 t/m

## In case of cross-over, actual track weight including plinths shall be considered for design.

## 6.2 SHRINKAGE & CREEP

Shrinkage and Creep effects will be calculated as per Clause 5.2.3 & 5.2.4 of IRS CBC.

## 6.3 PRE-STRESS FORCE (PR)

The pre-stressing force calculation will be as per Clause-16.8 of IRS-CBC. The loss of pre-stress due to friction will be calculated as per Clause-16.8.3 of IRS-CBC.

For calculation of long-term effects, the relative humidity to be considered as per Annexure A.7 of IRC 112 shall be  $(70(\text{max}) + 47(\text{min}))/2 = 58.5\%$

## 6.4 LIVE LOAD (LL) FOR METRO

### 6.4.1 Railway Vehicular Load

Each component of the structure shall be designed / checked for all possible combinations of these loads and forces. They shall resist the effect of the worst combination:

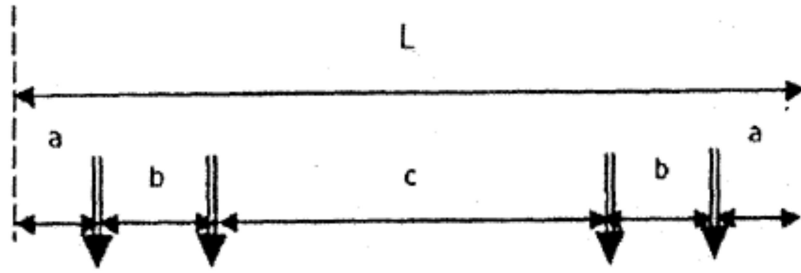

#### **All axle loads = 17 tons**

Maximum number of successive cars=6

Where,

$L = 22.340\text{m}$  (Length of a car)

$a = 1.920\text{m}$  (overhang)

$b = 2.500\text{m}$  (Wheel base in a bogie)

$c = 13.500\text{m}$  (Distance between Axle-2 and Axle-3 in the car)

Moving load analysis shall be carried out in order to estimate the maximum longitudinal force, max shear and max BM. The simply supported structures shall be designed for Medium Metro Loading Envelopes as tabulated in Annexure-I of Model DBR of RDSO.

In case of Twin U-Girder, each U-Girder will support only one track.

These superstructures and sub-structures will be checked for one track loaded condition as well as both tracks loaded condition (Single Span as well as Both Spans loaded condition).

However, for any other configuration (Axle load, and Axle spacing) of Modern Rolling stock including maintenance, machinery, crane etc., shall be within the loading envelope of present live load configuration.

#### **6.4.2 Dynamic Augmentation**

CDA will be considered as specified in clause 2.4.1.1 of IRS Bridge Rule. No reduction for double track loading will be considered.

#### **6.4.3 Footpath Live Load**

Footpath live load shall be taken as 490 kg/sqm. as per clause 2.3.2 of IRS Bridge Rules. As footpath live load is to be considered with carriageway live load without impact, this design will not be critical for any design except the parapet. The parapet will be designed for this loading.

#### **6.4.4 Longitudinal Force**

Braking load is taken as 18% of the unfactored Axle load.

Traction load is taken as 20% of the unfactored Axle load.

Since both the tracks are supported by a single girder, hence tractive force of one track and braking force of another track will be taken in the same direction to produce worst condition of loading.

As per Clause-2.8.5 of IRS-Bridge Rules, in transverse / longitudinal seismic condition, only 50% of gross tractive effort/braking force will be considered.

Dispersion, of longitudinal forces is not allowed as per Clause-2.8.3.4 of IRS Bridge Rules.

#### **6.4.5 Centrifugal Forces Due to Curvature of Superstructure**

The horizontal centrifugal force due to moving load in curved superstructure is to be considered as per § 2.5 of IRS: BR.

$$C = \frac{W v^2}{127 R}$$

Where  $W$  is Live load reaction &  $C$  is Centrifugal force (unit of  $C$  &  $W$  shall be same),  $v$  is maximum design speed in km/h and  $R$  is radius of curvature in m. This force is assumed to act at a height of 1.830 m above rail top level on safer side.

Design Speed of Live load of 95 km/h will be considered for computation of centrifugal force for curvature up to 450m radius. For sharper curves, speed restrictions as per SOD shall be followed.

#### **6.4.6 Racking Force**

The horizontal transverse loading due to racking specified in IRS-Bridge Rules Clause-2.9 is applicable to design of lateral bracing.

#### **6.4.7 Loads for flyover structure**

The design loading for the flyover in general have been considered in accordance with IRC: 6-2014 (Loads and Stresses) so as to sustain the most critical combinations of various loads and forces, given in Annex 3 of IRC: 6-2017.

##### **A. Dead Load (DL)**

The dead load includes self-weight of the members estimated on the basis of unit weight of the material specified in section 4 above.

##### **B. Super Imposed Dead Load (SIDL)**

###### **Wearing Course**

The wearing coat over the superstructure is 56 mm thick and load considered in the analysis and design is estimated with a unit weight 22 kN/m<sup>3</sup>

$$\text{Weight of wearing coat} = 0.056 \times 22 = 1.23 \text{ kN/m}^2$$

###### **Crash Barrier**

New Jersey type crash barriers as per details in IRC: 5 [Fig. 4 (a)] (P1 type-“Normal Containment Category) are provided on all structures. The crash barriers are designed for loads in accordance with as per Table 4 of IRC: 6-2017.

##### **C. Live Load**

Live load is applied on the structure as per live load combinations mentioned in Table 2 of

IRC: 6-2017.

Considering the carriageway to be a restricted 4-Lane/ 6-Lane divided carriageway, following live loads on the bridge are considered with impact factor as per IRC: 6-2017 and governing of all these is considered in the design.

### **Class A and Class 70 R Vehicle**

Two/Three traffic lanes in each direction operates on the four/six lane carriageway. Reduction as specified in clause 205 of IRC: 6-2017 for multi-lane loading shall be followed.

Minimum clear distance between the edges of passing vehicles shall be taken as specified in IRC:6 – 2017 for Class A vehicles and Class 70R vehicles.

Combination of Live Load Vehicles for different lanes of carriageway shall be as per Cl. 204.3 of IRC: 6-2017.

The design for special vehicle in this project is not warranted as at grade level, 2 lane road is available in each direction all along the length of this corridor and hence not considered for the analysis.

### **Braking/Traction Force**

Braking effect resulting from the application of brakes to vehicles on any carriageway or tractive effort caused through acceleration of vehicles in adjacent carriageway is considered to produce the worst effect on bridge structure.

As per clause 211.2 of IRC :6-2017, for every two lanes of any carriageway braking force shall be equal to twenty percent of the first train load on single lane plus ten percent of the load of the succeeding trains or part thereof in that lane.

Traction loads in the adjacent span are taken as same as braking loads. Braking and traction loads act 1.2 m above roadway along a line parallel to it.

Effect of live load impact is not considered for the calculation of braking and traction loads.

### **Centrifugal force**

The bridge situated on curve will be subjected to centrifugal action of moving vehicles which is determined as per section 212 of IRC: 6-2017.

## **6.5 TEMPERATURE EFFECTS**

### **6.5.1 Overall Temperature (OT)**

The loads shall be considered as per Clause-2.6 of IRS-Bridge Rules and Clause-215 of IRC: 6. Temperature variation of  $\pm 35^{\circ}\text{C}$  will be considered details of which are given below

Maximum Temperature considered as per Annex. F of IRC 6:2017:  $+47.8^{\circ}\text{C}$

Minimum Temperature considered as per Annex. F of IRC 6:2017:  $-0.4^{\circ}\text{C}$

Temperature variation as per clause 215.2 of IRC 6 will be  $=(47.8-(-0.4))/2+10=\pm 34.1^{\circ}\text{C}$  **say  $35^{\circ}\text{C}$ .**

## 6.5.2 Differential Temperature (DT)

The provision given in § 215.4 of IRC 6 – 2017, shall be considered to compute effect of differential temperature gradient in absence of any provisions in IRS code. The differential gradient of temperature along depth of superstructure has been reproduced below for ready reference. Short term modulus of elasticity as per Table given under clause 5.1 of DBR shall be used to calculate the effects.

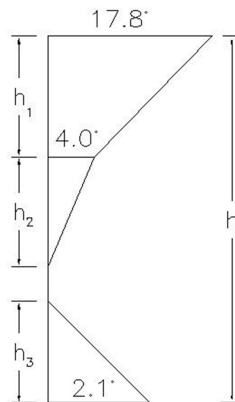

### Positive Temperature Difference

$$h_1 = 0.3h < 0.15\text{m}$$

$$h_2 = 0.3h > 0.1\text{m} < 0.25\text{m}$$

$$h_3 = 0.3h < 0.15\text{m}$$

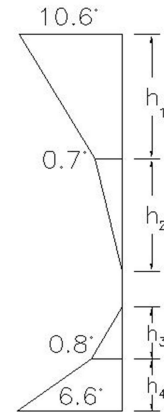

### Negative Temperature Difference

$$h_1 = h_4 = 0.2h < 0.25\text{m}$$

$$h_2 = h_3 = 0.25h < 0.25\text{m}$$

*Note: For purpose of these calculations no reduction shall be made for Metro Viaduct due to presence of track plinths. However, reduction for Flyover Viaduct is permitted due to presence of wearing coat thicker than 50mm.*

### Temperature Difference for Concrete Bridge Decks

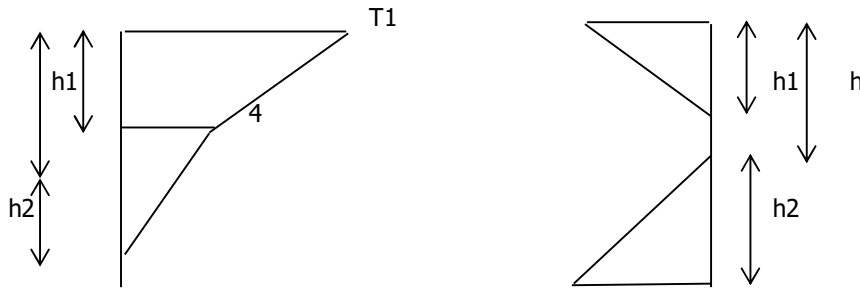
**Positive Temperature Difference**

$$h1 = 0.6h$$

$$h2 = 0.4h$$

H(m)	T1°C
0.2	18
0.3	20.5

**Negative Temperature Difference**

H(m)	T1°C
0.2	4.4

**Temperature Difference across Steel and Composite Sections**

*Note: For purpose of these calculations no reduction shall be made for Metro Viaduct due to presence of track plinths. However, reduction for Flyover Viaduct is permitted due to presence of wearing coat thicker than 50mm.*

**6.5.3 Resistance to Movement of Elastomeric Bearings (BS)**

Elastomeric bearing will resist movement/deformation of superstructure other than applied load i.e. due to variation of temperature/creep strain/shrinkage strain etc. The bearing resistance shall be calculated as per Clause-211.5.1.3 of IRC: 6.

The bearing resistance will produce lateral force on the substructure and foundation. The bearing resistance shall be calculated as  $(V_L \cdot \delta_L - V_R \cdot \delta_R)$ , where  $V_L$  and  $V_R$  are the shear rating of the left and right elastomeric bearings respectively and  $\delta_L$  and  $\delta_R$  are the deck movement at elastomeric bearing location. The above force will be zero when both side spans & supporting bearings are identical, in such case 10% of  $V_L \cdot \delta_L$  shall be considered for design of substructure and foundation

**6.5.4 Rail Structure Interaction (LWR Forces)**

Guidelines vide BS Report No. 119 "RDSO Guidelines for carrying out Rail-Structure Interaction studies on Metro System (version-2)" shall be followed.

A rail structure interaction [RSI] analysis is required because the continuously welded running rails are continuous over the deck expansion joints. The interaction occurs because the rails are directly connected to the decks by fastening system.

1. Rail structure interaction studies shall be done as per provisions of "RDSO Guidelines for carrying out Rail-Structure Interaction studies on Metro System (version-2)". The following shall be adhered to:

- a) Track resistance in loaded and unloaded conditions shall be obtained from cl. 3.2.6 Track Stiffness of "RDSO Guidelines for carrying out Rail-Structure Interaction studies on Metro System (version-2)". As per the clause, the recommended values for track stiffness for ballasted tracks are 60kN/m and 20kN/m for loaded and unloaded track respectively and

recommended values of track stiffness for ballast less tracks are 60kN/m and 40kN/m for loaded and unloaded tracks respectively. The elastic limit is 2 mm for ballasted tracks and 0.5 mm for ballast less tracks. No change in track stiffness is permitted on account of actual track behavior.

- b) The temperature variations, to be used for analysis, shall be taken as per provisions of cl. 3.2.8 Temperature Variations of "RDSO Guidelines for carrying out Rail-Structure Interaction studies on Metro System (version-2)". The following shall be used for analysis:

-The temperature of the bridge does not deviate from the reference temperature by more than  $\pm 35^{\circ}\text{C}$

-The temperature of the rail does not deviate by more than  $\pm 50^{\circ}\text{C}$ .

-The difference in temperature between deck and track does not exceed  $\pm 20^{\circ}\text{C}$ .

-The reference temperature is the temperature of the deck and the rail when the rail is fixed.

- c) Maximum additional stresses in rail in tension as well as compression on account of rail-structure interaction shall be within the permissible limits as prescribed in cl. 3.3.1 Additional Stresses in Rails of "RDSO Guidelines for carrying out Rail-Structure Interaction studies on Metro System (version-2)". The limit prescribed in the document shall be used as it is and no benefit on account of lesser axle load of actual rolling stock shall be permitted.
- d) The provisions of cl. 3.3.2 Displacements of Bridge Elements of "RDSO Guidelines for carrying out Rail-Structure Interaction studies on Metro System (version-2)" shall be adhered to.
- e) Checks must be performed for break in rail continuity due to unusual conditions such as fractures or for maintenance purposes. The provisions of cl. 4.8 "Rail Gap Analysis of RDSO Guidelines for carrying out Rail-Structure Interaction studies on Metro System (version-2)" shall be followed.
- f) Minimum (unfactored) LWR force of 1.6t/m of span length shall be considered for design irrespective of number of tracks.

2. Software and general methodology to be used for carrying out Rail Structure interaction analysis must be validated before adopting the same. A well-established document such as UIC 774-3R may be used for validation.

3. Representative stretches must be chosen for carrying out Rail-Structure interaction which shall include special spans. The same shall be got approved from the engineer.

4. LWR forces shall be considered in appropriate load combinations as specified in cl. 7.0 Load Combinations (Ground IIIb) of the DBR.

## 6.6 WIND LOAD (WL)

The wind load shall be calculated as per § 2.11 of IRS: BR and IS: 875 (Part 3).

As per § 5.3 of IS: 875 (Part 3)

Design Wind Speed,  $V_z = V_b \cdot k_1 \cdot k_2 \cdot k_3 \cdot k_4$

Where,  $V_b$  = Basic wind speed = 50 m/s for Delhi Zone (as per National Building code).

$k_1$  = 1.07 for class IV type structure (§ table 1 of IS: 875 (Part 3)).

$k_2$  = 1.07 for category 2 (§ table 2 of IS: 875 (Part 3)) for 20m Height.

$k_3$  = 1.12 for category 2 (§ table 2 of IS: 875 (Part 3)) for 30m Height

$k_4$  = 1.0 (§ 6.3.3.1 of IS: 875 (Part 3)).

$k_4$  = 1.0 (for non-cyclonic zone as per clause 6.3.4)

However, a bridge shall not be considered to be carrying any live load when the wind pressure at deck level exceeds  $150\text{kg/m}^2$  as per clause 2.11.2 of IRS Bridge rule, however as it is a long viaduct therefore there is fair possibility that once wind pressure exceeds  $150\text{kg/m}^2$  train may be standing static over viaduct due to close of operation therefore in case of wind pressure above  $150\text{kg/m}^2$ , train will be considered as static load i.e. no longitudinal loads or impact loads.

Wind load on train in transverse direction will be calculated based on exposed surface & intensity as per above given values & reference. These are computed for length of train as seen in elevation normal to longitudinal axis. The transverse load will be applied to train at center of projected area of the vehicle.

As per clause 209.3.4 of IRC: 6 the longitudinal wind load on Superstructure will be considered as 25% of Transverse load for Beam/Box/ Plate girder bridges. In case of Truss Bridges longitudinal load on Superstructure will be considered as 50%.

As per clause 209.3.6 of IRC: 6 the longitudinal wind load on Live Load will be considered as 25% of Transverse Wind load considered on Live load.

In case of Pier & Pier cap full load will be considered.

The longitudinal load will be acted simultaneously with transverse load.

### **Wind Load for flyover structure**

Wind loading acting on exposed areas of superstructure, substructure and live load is calculated in accordance with the clause 209 of IRC:6-2017. The transverse wind force acting at the centroids of appropriate area will be calculated using clause 209.3.3 and the longitudinal effects will be evaluated using clause 209.3.4 of IRC:6- 2017.

Upward and downward vertical wind load acting at the centroid of the appropriate areas for superstructure shall be derived as per clause 209.3.5 of IRC: 6-2017. Also clause 209.4 of IRC: 6-2017 will be referred to evaluate wind induced effect on substructure.

As per clause 209.3.7 of IRC:6-2017, bridges shall not be considered to carry any live load when wind speed at deck level exceeds 36m/s. Accordingly, following two cases for arriving at governing wind load are considered.

The effects of wind load with LL and wind loads without live loads shall both be considered as per IRC: 6:2017.

## **6.7 SEISMIC FORCE (EQ)**

The purpose of this section is to summarize the methodology and the assumptions that shall be used for the seismic analysis.

### 6.7.1 Seismic Design

Seismic design philosophy as stated in "Indian Railway Standard code for Earthquake resistant design of Railway Bridges 2017" has been considered. The peak ground acceleration denoted as zone factor is taken as 0.24 since Delhi is situated in zone IV of seismic map of India.

Seismic Checks shall also be done as per IRC: SP-114-2018 : Guidelines for Seismic Design of Road Bridges.

### 6.7.2 Definition of Seismic Input

Response spectrum ( $S_a/g$  vs  $T$ ) as prescribed in IRS Seismic code 2017, shall be used for seismic load computation.

### 6.7.3 Horizontal Seismic Coefficient

The horizontal seismic design coefficient shall be calculated as per following expression

$$A_h = (Z/2) * (I/R) * (S_a/g)$$

Where,

- $A_h$  = horizontal seismic coefficient to be considered in design  
 $Z$  = peak ground acceleration or zone factor = 0.24  
 $I$  = importance factor = 1.5  
 $R$  = response modification factor as per Table 3  
 $S_a/g$  = normalized pseudo spectral acceleration for corresponding to relevant damping of load resisting elements (pier/columns) depending upon the fundamental period of vibration  $T$   
 Damping factor = 5% for reinforced concrete piers.

### 6.7.4 Response Reduction Factor

Response Reduction Factor "R" as per IRS Seismic code 2017 Table -3 shall be as given below

S.No.	Elements	Response Reduction Factor "R"
1	RCC Pier with ductile detailing	3.0
2	PSC Pier/Pier cap/Portal beam	2.0
3	Portal Pier with ductile detailing (Beam integral with pier)	3.0-In Longitudinal direction 4.0-In transverse direction
4	Bearing	2.0
5	Stopper	1.0
6	Foundations	2.0

Note: In addition to the response reduction factor given above, reinforcement detailing of Piers/Portal Piers shall conform to ductility requirements as per Annexure-B of Indian Railway Standard code for Earthquake resistant design of Railway Bridges 2017.

### 6.7.5 Vertical Seismic Coefficient

The seismic zone factor & time period (of Vertical motion) for calculating vertical seismic coefficient shall be considered as per clause 7.3.2 & 9.4.2 of IRS seismic code. The Zone factor for calculating the vertical seismic coefficient will be  $2/3 \times \text{Zone factor}$  i.e.  $2/3 \times 0.24 = 0.16$ .

### 6.7.6 Computation of Fundamental period of vibration

The fundamental time period shall be calculated by any rational method of analysis. Each pier is considered as a single degree of freedom oscillator with mass placed at the Centre of Gravity (COG) of the deck.

The time period can also be calculated based on expression given in Clause 8.1 of Seismic Code 2017, which is as follows:

$$T = 2\pi \sqrt{\delta/g}$$

Where,

$\delta$  = horizontal displacement at top of pier due to horizontal force.

#### a) Mass

- Permanent masses (Self Weights, SIDL) of:
  - (a) Full span longitudinally, which can be resisted by reaction blocks or POT/Spherical bearings during earthquake, at one side of the pier or half of spans on either side of pier in case seismic is resisted by bearings (For longitudinal seismic)
  - (b) Half of spans on either side of pier (For transverse seismic)
- Mass of the pier cap
- 80% mass of the pier
- The earth quake acceleration will be considered on full mass and not buoyant mass.

It may be noted that while calculating lateral seismic forces, 50% live load is included in the seismic weight for transverse direction i.e. Minimum live load among 4 cases i.e. OSOT (one span one track), OSBT (One span both tracks), BSOT (Both span one track) & BSBT (Both span both tracks) will be considered, whereas no live load is included for seismic weight in longitudinal direction.

As per clause 2.8.5 of IRS: Bridge Rule, in transverse/ longitudinal seismic condition, only 50% of gross tractive effort / braking force/centrifugal force/racking force shall be considered.

#### b) Stiffness

- Stiffness shall be calculated with the concrete instantaneous modulus of elasticity, for all structural elements.
- Pier stiffness considering fixed base and free at deck location  $K = 3EI_{\text{eff}}/L^3$
- $I_{\text{eff}} = 0.75I_g$ , as per clause 5.2.1 of IRC: SP: 114-2018. In the calculation of fundamental time period, effective moment of inertia is considered.
- Flexibility of foundation soil system may be considered while calculating time period i.e. foundation and soil spring may be modelled while calculating time period.

The static stiffness of soil spring shall be calculated as per Table-3 of Annexure-C of IS 2911 Part-1 (Section 2). While calculating the static soil stiffness, soil shall be considered as dry granular soil (for time period calculation) with uniform N values of 25

throughout the depth for all cases. In liquefaction zone no soil spring shall be considered.

Only for calculating the time period, dynamic stiffness ( $K_{dynamic}$ ) shall be used and it shall be taken as 3.5 times the static stiffness ( $K_{static}$ ) i.e  $K_{dynamic} = 3.5 * K_{static}$ .

For calculating seismic forces and its effects the static value of soil springs as per clause 12.4.2 of the DBR shall be used.

- Time period of more than 4s shall not be allowed in any case; section needs to be resized when it exceeds 4s.

### 6.7.7 Direction Combinations

The seismic forces shall be assumed to come from any horizontal direction. For this purpose, two separate analyses shall be performed for design seismic forces acting along two orthogonal horizontal directions. The design seismic force resultant (that is axial force, bending moment, shear force and torsion) at any cross section of a bridge component resulting from the analysis in the two orthogonal horizontal directions shall be combined according to the expressions given below.

- $\pm EL_x \pm 0.3 EL_y$
- $\pm 0.3 EL_x \pm EL_y$

Where

$EL_x$  = Force resultant due to full seismic force along X direction, and

$EL_y$  = Force resultant due to full seismic force along Y direction

When vertical seismic forces are also considered, the design seismic force resultants at any cross-section of a bridge component shall be combined as below:

- $\pm EL_x \pm 0.3 EL_y \pm 0.3 EL_z$
- $\pm 0.3 EL_x \pm EL_y \pm 0.3 EL_z$
- $\pm 0.3 EL_x \pm 0.3 EL_y \pm EL_z$

Where  $EL_x$  and  $EL_y$  are as defined above and  $EL_z$  is the force resultant due to full seismic force along vertical direction.

As an alternative to the procedure given above, the forces due to the combined effect of two or three components can be obtained on the basic square root of sum of square (SRSS)

$$\sqrt{(EL_x^2 + EL_y^2)} \quad \text{or} \quad \sqrt{(EL_x^2 + EL_y^2 + EL_z^2)}$$

The vertical seismic coefficient for the design of horizontal cantilever structural elements shall be considered as per Clause 7.3 of IRS: CBC.

## 6.8 ERECTION TEMPORARY LOADS (ETL)

Erection forces and effects shall be considered as per Clause-2.13 of IRS-Bridge Rules.

The weight of all permanent and temporary materials together with all other forces and effects which can operate on any part of structure during erection shall be considered in design. The

loads arising from most onerous conditions of the construction methods adopted is awaited from the Contractor.

Special care shall be taken that no damage is caused by the construction contractor to the permanent structure. In case of any hole etc., drilled in permanent structural element, the same will be made good by using non-shrink, expansive, high strength grout and its strength shall be better than the structural element and will have to be demonstrated.

### **6.9 DERAILMENT LOADS (DR)**

For vertical considerations, check shall be made in accordance with the IRS-Bridge Rules, Appendix-XXV with standard gauge in place of Broad gauge. For ULS and stability check, loading shall be proportional as per maximum axle load. This derailment load corresponds to an ULS load for SLS combinations (Group-V of IRS-CBC) a 1/1.75 coefficient will be applied to the derailment load. The Sacramento criteria need to be considered for U-Girder.

### **6.10 FORCES ON PARAPET**

The parapets shall be designed to resist lateral horizontal force & a vertical force of 1.50 kN/m applied simultaneously at the top of the parapet as per Clause 2.10 of IRS Bridge Rules.

### **6.11 DIFFERENTIAL SETTLEMENT (DS)**

Differential Settlement between two adjacent viaduct piers shall be as follows.

- i) 12mm for Long Term Settlement;
- ii) 6 mm for Short Term Settlement

The allowable settlement for pile group is 25mm (as per IS 2911-part 4); hence differential settlement between two foundations is considered as half of 25 mm i.e. 12 mm as long-term settlement. The short-term settlement of 6mm is considered to cater for bearing replacement condition.

Differential settlement shall be considered only in the design of continuous structures, if any.

### **6.12 BUOYANCY LOADS**

The design of the foundation shall be done considering design ground water table as referred in clause 5.5 of the DBR.

In case of river bridges, stability check and calculation of base pressure, full buoyancy shall be considered on submerged portion of substructure and foundation up to HFL or LWL as the case may be, irrespective of the type of soil on which the foundation will rest.

Hydro dynamic forces will be considered as per clause 6 of IRS Seismic code.

### **6.13 WATER CURRENT FORCES**

Water current force in submerged portion of substructures and foundations shall be calculated as per Clause 5.9 of IRS Bridge Substructure & Foundation Code

### **6.14 VEHICLE COLLISION LOAD (VCL)**

The vehicle collision load on piers: as per Clause-222 of IRC: 6.

Rules specifying the loads for design of superstructure and sub-structure of bridges and for assessment of the strength of existing bridges should be done as per IRS: Bridge Rules.

All structure near railway track shall be checked for accidental impact from derailed trains as per clause 2.16.4 of IRS Bridge Rules as per Addendum & Corrigendum Slip No. 48 dated 22.06.2017.

### 6.15 GRADIENT EFFECT

The bearing shall be sandwiched between two true horizontal surfaces. Steel Wedge shall be provided to cater longitudinal slope of superstructure.

### 6.16 BUFFER LOAD

Provision of Buffers is contemplated at the end of temporary terminal stations during stage opening of the Corridors, at Pocket track ends and at the terminal stations of the corridors (at the end of turn back/stabling lines). Such buffers will be of friction type. These buffers will be designed to have stopping performance based on mass of fully loaded train and its declaration to avoid damage to the train or buffer. Viaduct elements need to be designed for such Buffer load. The exact Buffer loads need to be interfaced and ascertained during the detailed design.

### 6.17 VIBRATION EFFECT

Effect of vibration due to movement of train on Viaduct structure will be taken into consideration. This will be checked in dynamic analysis.

## 7 LOAD COMBINATIONS

7.1 **Methodology:** Provisions of IRS-CBC shall be followed. The partial load factors and load combinations shall be as per Clause-11 and Table-12 of IRS-CBC as modified and shown below:

Load	Abbreviations
Dead load	DL
Super imposed dead load	SIDL
Prestressing	PS
Live Load	LL
Live load on footpath	LFP
Longitudinal force ( Traction & Braking)	LF
Centrifugal force	CF
Over all temperature	OT
Differential Temperature	DT
Long welded rail force	LWR
Racking Forces	RF
Wind forces	WL
Earthquake	EQ
Differential settlement	DS
Derailment	DR
Erection load	ER

Limit state	Loads	Symbol	G I	G II (EQ)		G II (WL)		G III (a)	G III (b)	G V
				G IIa (EQ)	G II b (EQ)	G IIa (WL)	G II b (WL)	Temperature	LWR	
SLS Combinations	Dead Loads	DL	1.00	1.00	1.00	1.00	1.00	1.00	1.00	1.00
	Prestressing	PS	1.00	1.00	1.00	1.00	1.00	1.00	1.00	1.00
	Super Imposed Loads (fixed)	SIDL-1	1.00	1.00	1.00	1.00	1.00	1.00	1.00	1.00
	Super Imposed Loads (variable)	SIDL-2	1.20	1.20	1.20	1.20	1.20	1.20	1.20	1.20
	Earthquake	EQ		1.00	1.00					
	Overall T	OT						1.00	1.00	
	LWR								1.00	
	Differential DT	DT						0.80	0.80	
	Differential settlement	DS	1.00							
	Live load	LL	1.10		0.50		1.00	1.00	0.50	
	Live load on footpath	LWP	1.00		0.50		1.00	1.00	0.50/ 1.00 (##)	
	Derailment Loads	DR								1.00(**)
	Wind Load						1.00	1.00		
ULS Combinations	Dead Loads	DL	1.25	1.25	1.25	1.25	1.25	1.25	1.25	1.25
	Prestressing	PS	1.15/0.87 <sup>(*)</sup>	1.40	1.40	1.15/0.87 <sup>(*)</sup>	1.15/0.87 <sup>(*)</sup>	1.15/0.87 <sup>(*)</sup>	1.15/0.87 <sup>(*)</sup>	1.15/0.87 <sup>(*)</sup>
	Super Imposed Loads (fixed)	SIDL-1	1.25	1.25	1.25	1.25	1.25	1.25	1.25	1.25
	Super Imposed Loads (variable)	SIDL-2	2.00	2.00	2.00	2.00	2.00	2.00	2.00	2.00
	Earthquake	EQ		2.00#	2.00#					
	Overall T	OT						1.50	1.50	
	LWR								1.50	
	Differential DT	DT						1.15	1.15	
	Differential settlement	DS								
	Live load	LL	1.75		0.50		1.40	1.40	0.70	
	Live load on footpath	LWP	1.50		0.50		1.25	1.25	0.6125	
	Derailment Loads	DR								1.00
	Wind Load						1.60	1.25		

In each of SLS and ULS cases, 5 basic load combination groups shall be considered, according to the IRS- CBC.

(\*) 1.15/0.87: In accordance with IRS CBC article 11.3.3., when the Prestressing PR increases the section capacity vs. shear then PR is multiplied by 0.87. When the Prestressing PR decreases the section capacity vs. shear then PR is multiplied by 1.15.

#The calculation for seismic force will be done considering  $Z/2$ , however as MCE is proposed to be used only in ULS case as per IRS seismic code, the load factor is modified to 2.0. This is done for ease of calculation.

Notes:

- 1) ULS-Ultimate Limit state.
  - 2) SLS-Serviceability Limit state
  - 3) Wind load and earth quake loads shall not be assumed to be acting simultaneously.
  - 4) Live load shall also include dynamic effect, force due to curvature exerted on tracks, longitudinal forces, braking forces and forces on parapet.
  - 5) Crack width check shall be done in SLS case for combination G I only.
- 7.2 The Superstructure/bearing, sub-structure and foundation will be checked for one track loaded condition as well both track loaded condition, for single span and both spans loaded conditions, as the case may be.
- 7.3 Design of viaduct shall be done in accordance with the construction methodology/ construction sequence to be adopted during execution.
- 7.4 The analysis and design will be carried out for all possible cases of rolling train loads. All the supporting structures, such as superstructure, bearings, substructure and foundations shall be checked for the most onerous cases.

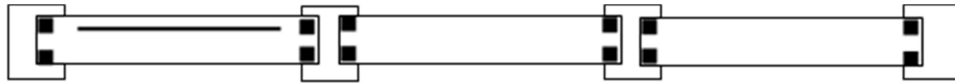

**LL1:** used for Deck Torsion, Bearing Compression, Uplift, Shaft check, Foundation check

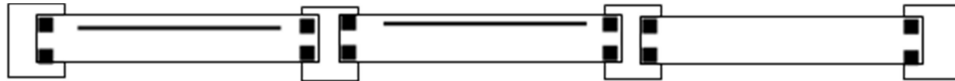

**LL2:** LL2 used for Shaft check, Foundation check

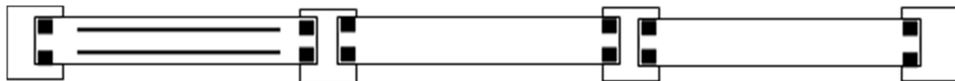

**LL3:** used for Deck check, Bearing Compression check, Shaft check, Foundation check;

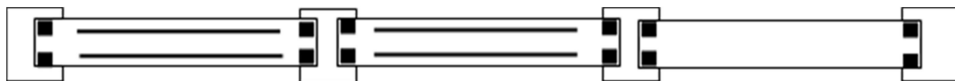

**LL4:** used for shaft check, Foundation check, Shear Key check

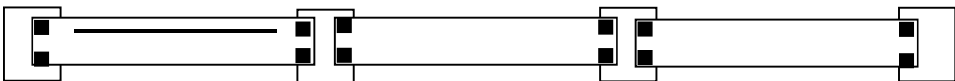

### **Load Combinations for flyover structure**

The load combinations for the design of various superstructure elements are taken as per Annex-B of IRC: 6-2017 for Limit State of Design.

#### **ULS COMBINATIONS**

(as per Table B.2 of IRC: 6-2017)

No	Load Description	LOAD FACTORS											
		Combination I (Additive)					Combination II (Relieving)					Seismic Combination	Accidental combination
		Max Wind & No LL	LL Leading with Temperature	Temperature Leading with LL	LL Leading with Wind	Wind Leading with LL	Max Wind & No LL	LL Leading with Temperature	Temperature Leading with LL	LL Leading with Wind	Wind Leading with LL		
1	<i>Dead Load</i>	1.35	1.35	1.35	1.35	1.35	1	1	1	1	1	1.35	1
2	<i>SIDL</i>	1.35	1.35	1.35	1.35	1.35	1	1	1	1	1	1.35	1
3	<i>Surfacing</i>	1.75	1.75	1.75	1.75	1.75	1	1	1	1	1	1.75	1
4	<i>Temperature Overall</i>		0.9	1.5				0.9	1.5			0.5	0.5
5	<i>Temperature Gradient</i>		0.9	0.9				0.9	0.9			0.5	0.5
6	<i>Braking</i>		1.5	1.15	1.5	1.15		1.5	1.15	1.5	1.15	0.2	0.2
7	<i>Wind- without LL</i>	1.5					1.5						
8	<i>Wind- with LL</i>				0.9	1.5				0.9	1.5		
9	<i>Live Load</i>		1.5	1.15	1.5	1.15		1.5	1.15	1.5	1.15	0.2	0.2
10	<i>Accidental Load</i>												1
11	<i>Seismic Load</i>											1.5	

**SLS COMBINATIONS**

SLS Rare Combinations (as per Table B.3 of IRC: 6-2017)

No	Load Description	LOAD FACTORS														
		Rare Combinations														
		Max Wind & No LL		LL Leading with Temperature Rise		LL Leading with Temperature Fall		LL Leading with Wind		Wind Leading with LL		Temperature Leading with LL - Temperature Rise		Temperature Leading with LL - Temperature Fall		
		Adding	Relieving	Adding	Relieving	Adding	Relieving	Adding	Relieving	Adding	Relieving	Adding	Relieving	Adding	Relieving	
1	<i>Dead Load</i>	1	1	1	1	1	1	1	1	1	1	1	1	1	1	1
2	<i>SIDL</i>	1	1	1	1	1	1	1	1	1	1	1	1	1	1	1
3	<i>Surfacing</i>	1.2	1	1.2	1	1.2	1	1.2	1	1.2	1	1.2	1	1.2	1	1
7	<i>Temperature Overall</i>			0.6	0.6							1	1			
9	<i>Temperature Gradient</i>			0.6	0.6							1	1			
11	<i>Wind- without LL</i>	1	1													
12	<i>Wind- with LL</i>							0.6	0.6	1	1					
13	<i>Braking</i>			1	1	1	1	1	1	0.75	0.75	0.75	0.75	0.75	0.75	0.75
14	<i>Live Load</i>			1	1	1	1	1	1	0.75	0.75	0.75	0.75	0.75	0.75	0.75
15	<i>Settlement Effects</i>	1	0	1	0	1	0	1	0	1	0	1	0	1	0	0

**SLS Quasi-Permanent Combinations for Superstructure (as per Table B.3 of IRC: 6-2017)**

Load Case	Load Description	Load Factors			
		Quasi-permanent			
		Permanent		Temperature	
		Adding	Relieving	Adding	Relieving
1	<i>Dead Load</i>	1	1	1	1
2	<i>SIDL</i>	1	1	1	1
3	<i>Surfacing</i>	1.2	1	1.2	1
4	<i>Temperature Overall</i>			0.5	0.5
5	<i>Temperature Gradient</i>			0.5	0.5
6	<i>Settlement</i>	1	0	1	0

**COMBINATIONS FOR VERIFICATION OF EQUILIBRIUM**

Equilibrium Combinations (as per Table B.1 of IRC: 6-2017)

Sr. No	Load Description	LOAD FACTORS													
		Basic Combination								Accidental Combination		Seismic Combination		Construction Condition	
		LL Leading with Wind		LL Leading with Temperature		Temperature Leading with L.L		Wind Leading with LL							
		Overturning	Restoring	Overturning	Restoring	Overturning	Restoring	Overturning	Restoring	Overturning	Restoring	Overturning	Restoring	Overturning	Restoring
1	<i>Dead Load</i>	1.1	0.9	1.1	0.9	1.1	0.9	1.1	0.9	1.0	1.0	1.1	0.9	1.1	0.9
2	<i>SIDL</i>	1.1	0.9	1.1	0.9	1.1	0.9	1.1	0.9	1.0	1.0	1.1	0.9	1.1	0.9
3	<i>Surfacing</i>	1.35	1.0	1.35	1.0	1.35	1.0	1.35	1.0	1.0	1.0	1.35	1.0	1.35	1.0
4	<i>Thermal Load</i>			0.9		1.5				0.5		0.5			
5	<i>Live Load</i>	1.5		1.5		1.15		1.15		0.75		0.2			
6	<i>Braking</i>	1.5		1.5		1.15		1.15		0.75		0.2			
7	<i>Wind</i>	0.9						1.5							
8	<i>Accidental Load</i>									1					
9	<i>Seismic Load</i>											1.5			
10	<i>Counter Weight</i>										1		1		0.9
11	<i>Construction DL</i>													1.05	0.95
12	<i>Wind Load</i>													1.5	

## 8 DESIGN CHECK FOR CONCRETE STRUCTURE

### 8.1 ALLOWABLE STRESSES FOR CONCRETE AT SERVICEABILITY LIMIT STATE (SLS)

The stresses at transfer and construction stage during service for prestressed cast in situ and segmental construction shall be as per Clause-16.4.2.2 (Concrete Compressive stress Limitations), Clause-16.4.2.3 (Steel stress Limitations), Clause-16.4.2.4 (Cracking), Clause-17.3.3 (Other types of Connections) and Clause-17.4 (Composite Concrete Constructions) of IRS-CBC.

Clause-10.2 (Serviceability Limit States) of IRS-CBC shall be used for RCC construction (Beams, Columns and Slabs).

**Permissible stresses for flyover superstructure and pier cap supporting the flyover girders shall be as per IRC:112**

#### Summary of Permissible Stresses

##### Precast or Cast-In-Situ Post-Tensioned Structures

No	Load Combination	Allowable compressive strength	Reference	Allowable tensile stress*	Reference
<b>At transfer and/or construction stage</b>					
1	DL +*DS + App.PR	0.5 fci but $\leq 0.4$ fck	CI 16.4.2.2(b) of IRS CBC 1997	<b>1 MPa*</b>	CI 16.4.2.4(b) of IRS CBC 1997
2	Group 1+50% EL	0.5 fci but $\leq 0.4$ fck	(CI 16.4.2.2(b) of IRS CBC 1997	<b>1 MPa*</b>	CI 16.4.2.4(b) of IRS CBC 1997
<b>During Service</b>					
3	SLS LC1	0.4 fck	(CI 16.4.2.2(a) of IRS CBC 1997	No tension anywhere	CI 16.4.2.4(b) of IRS CBC 1997
4	SLS LC2	0.4 fck	(CI 16.4.2.2(a) of IRS CBC 1997	No tension anywhere	CI 16.4.2.4(b) of IRS CBC 1997
5	SLS LC3	0.4 fck	(CI 16.4.2.2(a) of IRS CBC 1997	No tension anywhere	

\* In case of Segmental structures, no tension is permitted under any stage or any SLS Load combination as clause 17.3.3 of IRS-CBC.

\*\* In case of Uniform compressive stress distribution in PSC structures, permissible stress shall not be more than  $0.3f_{ck}$ .

#### II RCC Structures

Permissible stress in Concrete (triangular compressive stress distribution) -  $0.50f_{ck}$   
 Permissible stress in Concrete (Uniform compressive stress distribution) -  $0.38f_{ck}$

Permissible stress in Steel -  $0.75f_y$

## **8.2 ULS CHECK FOR PRESTRESSED CAST-IN SITU CONCRETE/COMPOSITE CONSTRUCTION**

Clause-16.4.3 (Ultimate Limit State: Flexure) to Clause 16.4.6 (Longitudinal Shear) of IRS-CBC shall be applicable for cast-in situ Prestressed construction whereas for composite construction Clause-17.4 (Composite Concrete Construction) shall be used.

## **8.3 ULS CHECK FOR RCC STRUCTURE**

Section Capacity check for RC beams (ULS) for the superstructure should be conforming to Clause-15.4 of IRS-CBC. The design of RCC slabs shall conform to Clause 15.5 of IRS-CBC. The design of column should conform to Clause-15.6 of IRS-CBC.

## **8.4 TYPES OF CONNECTIONS**

For connections between precast pier cap for flyover support and pier, clause 17.3.3 of IRS:CBC shall be applicable.

## **9 DESIGN CHECK FOR STEEL/COMPOSITE STRUCTURE**

The design of steel structure shall be done by IRS Steel Bridge Code/IRS-Welded Bridge Code. The design of composite structure shall be done by IRC: 22.

## **10 DURABILITY & CRACK WIDTH**

### **10.1 DURABILITY**

Provision of Clause-5.4 of IRS-CBC shall be followed. The exposure condition of present corridor is Moderate and in case of Nallah crossing the exposure condition may be treated as "Severe".

### **10.2 CRACK WIDTH CHECK**

For SLS Combination, Group - I, crack width in reinforced concrete members shall be calculated as per Clause-15.9.8.2.1 of IRS-CBC.

The allowable crack width should be as per Clause 10.2.1 (a) (CS-1-12/2014) based on the exposure condition defined in Clause 5.4.1 of IRS-CBC and table-10 of IRS-CBC.

For crack control in columns, clause15.6.7 of IRS-CBC will be modified to the extent that actual axial load will be considered to act simultaneously.

The crack width check of flyover super-structure and piercap supporting the girders, shall be done as per IRC:112

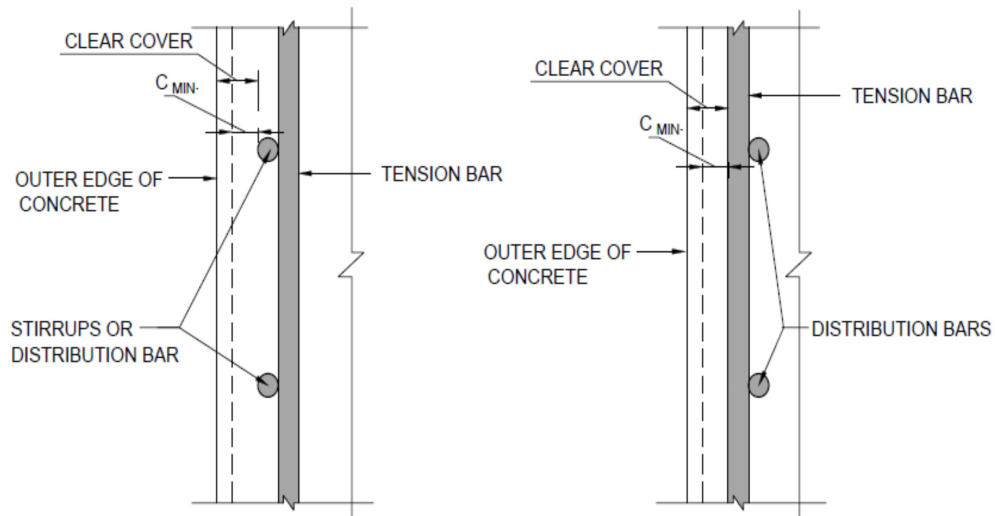

CASE -1: OUTER LAYER OF BAR  
BEFORE TENSION BAR

CASE -2: TENSION BAR  
OUTER LAYER

MEMBERS SUBJECTED TO ONE WAY BENDING.

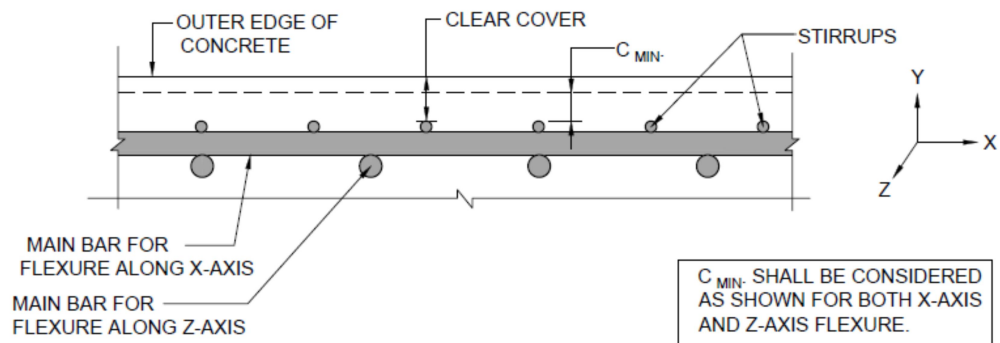

MEMBERS SUBJECTED TO TWO WAY BENDING.

### **CLEAR COVER AND $C_{MIN}$ FOR CRACK WIDTH CALCULATION**

#### **10.3 DEFLECTION**

The calculation of deflection shall be done in accordance with provisions of UIC-776 3R.

#### **11 FATIGUE**

##### **11.1 GENERAL**

Fatigue phenomenon shall be analyzed for those structural elements that are subjected to repetition of significant stress variation (under traffic load). Thus generally the fatigue shall be regarded only for deck structural part supporting the tracks.

## **11.2 PRESTRESSED CONCRETE STRUCTURE**

The fatigue shall be checked as per Clause-13.4 IRS-CBC. However, fatigue check for prestressed concrete structures does not need to be performed as long as the whole section (from top to bottom fiber) remains under compression under SLS load combination 1.

## **11.3 REINFORCED CONCRETE STRUCTURE**

The fatigue shall be checked as per Clause-13.4 of IRS-CBC.

Fatigue check for reinforced concrete structures does not need to be performed unless it is a main structure member (i.e. the deck) supporting the traffic that consists of reinforced concrete. The permissible stress range in unwelded reinforcement as per clause 13.4.1 of IRS CBC shall be 155Mpa up to 16mm diameter & 120Mpa for bars exceeding 16mm diameter.

## **11.4 STEEL/STEEL COMPOSITE STRUCTURES**

Clause-3.6 of IRS-Steel Bridge (up to latest correction slip) / Clause-13.2 of IRS-Welded Bridge code shall govern. If values are required to be used, the train closest to the actual train formation proposed to be run on the DMRC shall be used. Otherwise, detailed counting of cycles shall be done.

## **12 DESIGN METHODOLOGY**

### **12.1 SUPERSTRUCTURE SYSTEM OF VIADUCT**

The Superstructure of the viaduct comprises of simply supported Twin U-Girder.

However sharp curvature/ crossovers / turnouts/ railways crossings / highway crossings, PSC I -Girder/ Balanced Cantilever/Steel Composite girders/Steel Truss may be used. The minimum dimensions shall be considered as per Clause 16.9.6 of IRS-CBC.

Steel Diaphragms shall be provided in case of PSC T/I Girder Superstructure and stiffness of the same shall not be considered in the analysis.

Design of superstructure should be done in accordance with construction methodology/ construction sequence to be adopted during execution by DMRC.

#### **Drainage**

The drainage of deck shall be designed to cater the maximum envisaged rainfall intensity and suitable longitudinal and transverse slope should be provided. Moreover the provisions of Clauses-10.4.1.1 & 15.2.2 of IRS-CBC shall be followed.

#### **Solid Pier**

The drain pipe of double wall HDPE corrugated pipes with water collection box at top, shall be located within solid pier to avoid unpleasant aesthetics.

#### **Deck**

The top of soffit slab will be profiled so as to collect the run-off water at multiple points by providing a cross slope of 2.5%. Drainage pipes will be provided to collect the run-off.

## 12.2 BEARING SYSTEM AND ITS DESIGN METHODOLOGY

### a) Bearing System

Considering the span configuration and safety aspects of the structural system (in normal and seismic condition), it is proposed to adopt elastomeric bearings placed underneath the Twin U-Girder for transfer of vertical forces and in-plane forces. The elastomeric bearings shall not be designed for seismic forces and seismic forces will be transferred to substructure via shear key.

POT -PTFE bearing shall be designed as per IRC: 83 Part-III & Spherical bearing shall be designed as per IRC: 83 part-IV.

The elastomeric bearing shall be designed in accordance with EN 1337 part 1 and part 3 wherever required.

### b) Replaceability of Bearings

While finalizing the proposed bearing system, it shall be kept in mind that accessibility and replacement of each part of bearing are of paramount importance as the design life of bearings is shorter than that of the structure. Keeping in view the above cited criteria, all the bearings and pier caps will be detailed for replacement of bearings in the future. The end diaphragms shall be designed to facilitate the operations of jacks during maintenance as per clause 15.9.11.3 of IRS-CBC.

**Special Low Height jacks shall be employed to replace bearings, if minimum vertical clearance is less than 400 mm as stipulated in Clause-15.9.11.4 of IRS-CBC.**

### c) Uplift

If required a holding-down device connecting the deck and the pier head shall be placed in order to prevent the deck from overturning. The holding-down device may be integrated in the pot-bearing system or be a separate system constituted of bars embedded in pier cap and viaduct with appropriate details, permitting translation/rotation. Other systems can also be foreseen.

Due to the lack of appropriate guidelines in Indian codes, the design criteria for holding down device (upward force limit requiring holding down device, design formulas) will be taken from the latest international practice.

## 12.3 SUBSTRUCTURE SYSTEM

### a) Pier Cap

For designing the pier cap as corbel the provisions of Clause-17.2.3 of IRS-CBC should be followed. In case of shear span to effective depth ratio being more than 0.6, pier cap will be designed as flexural member.

Height of pedestal should be in between 150mm and 500mm as per clause 710.10.2 of IRC: 78.

The Pier cap shape shall be suitable at transition pier supporting different types of superstructure instead of providing raised/column pedestal over pier cap.

## b) Piers

The effective length of a cantilever pier for the purpose of slenderness ratio calculation will be taken as per Table-18 of IRS-CBC. In this project most of the columns are isolated columns with elastomeric bearing supporting the superstructure. In either direction the effective length will be taken as  $2.3L_0$  (case 7). Here  $L_0$  represent height of column from top of footing slab/Pile cap to top of pier cap. Effective length of portal column in longitudinal direction will be taken similar to single column i.e.  $2.3L_0$  and for transverse direction it should be taken as  $1.5 L_0$  (case 6).

The design of pier shall be done as per clause 15.6 of IRS CBC.

### Prestressed Cantilever Pier

In case of vertically prestressed piers, minimum longitudinal reinforcement shall be provided as RCC column as per clause 15.9.4.1 of IRS CBC.

Shear reinforcement & ductile detailing shall be done as that of RCC column.

In all SLS combinations, column shall remain in compression.

Clause 16.6.1 of IRS CBC shall be applicable in case of prestressed piers/columns.

## 12.4 FOUNDATION SYSTEM

Foundation shall be designed as per IRS Bridge Substructure & Foundation Code, IRS Concrete Bridge Code, IRC-78, Manual on the design and construction of well foundation; IS-2911 should be followed for design of foundations.

### 12.4.1 Pile Foundation

Foundation analysis and design will be based on IRS Code for Substructure & IRC-78. The forces applied by the pier are transferred to the bottom of the pile cap for this purpose. Reactions in pile are calculated using Rivet theory. The various specific assumptions made for the pile and pile cap design are as follows:

- a) Bored-cast-in-situ multiple pile groups will be adopted.
- b) Minimum 1.0m diameter bored cast-in-situ vertical piles in soil/rock have been contemplated for the foundation of piers. Minimum number of pile in each pile cap shall not be less than 4.
- c) Open foundation have been contemplated for the pier location with rocky strata at shallow depth.
- d) For piles and pile caps, load combinations shall be considered as per IRS-CBC, Table-12. The various specific assumptions made for the pile and pile cap design including pile load testing shall be as per IS: 2911, IRC-78 and IRS-Bridge Sub-structure and Foundation Code.
- e) For pile carrying capacity, all SLS Load combinations as per IRS-CBC will be considered.
- f) Increase in vertical load capacity of pile shall be done as per Table-1 of IS 1893-Part-1.

- g) The lateral load capacity of pile shall be evaluated either by using empirical formulae given in IS: 2911 (Part-1/ section-2) or by soil structure interaction analysis using Winkler's spring model by limiting the lateral deflection as 1% of Pile diameter as per Cl. 709.3.5.2 of IRC: 78.
- h) Initial load tests (not on working pile) will be conducted as per IS: 2911 - Part IV. Initial test is proposed to be conducted for a load of 2.5 times as per the safe vertical load based on static formula.
- i) The working load on pile for vertical and horizontal loads shall be verified through routine load tests during construction.
- j) In case of multiple pile system, spacing between the piles shall not be less than 3 times the diameter of pile in soil and 2.5 times the diameter when founded on rock.
- k) In general, the top of pile cap shall be kept about min 500mm below the existing ground level and weight of the earth cover will be applied on top of pile cap when unfavorable. The earth cover on pile cap for any favorable effect (stability, soil horizontal capacity.) will be neglected.
- l) The following limiting values shall not be exceeded for computation of safe load:
- Result of sub-structure investigation will be used for adopting the value of angle of internal friction " $\phi$ " and cohesion of soil " $c$ " as per clause 5.7 of the DBR .
  - Angle of wall friction  $\delta$  shall be taken as equal to  $\phi$  deg.
  - Co-efficient of earth pressure " $K$ " shall be taken as 1.0.
  - Maximum overburden pressure at bottom of pile for calculation of shaft resistance and bearing resistance shall be limited to 15 times the diameter of the pile. The maximum depth shall be considered from existing ground level.
  - For calculating the pile capacities, the design ground water table as per clause 5.5 of the DBR shall be considered.
  - Bulk density corresponding to 100% saturation shall be calculated and used for working out submerged density of soil.
- m) While finalizing length of pile, Clause 705.4.1 of IRC: 78 shall also be followed.
- n) Live load surcharge needs to be considered for pile group which is outside median and where live load is moving over pile cap. Normal Pile groups below median or where there is no live load over pile cap need not to be design for live load surcharge.
- o) In case of foundations near railway crossing effect of railway live load surcharge shall be considered if applicable

### **Structural Design**

- a) Pile design shall be done according to § 15.6 of IRS CBC 1997. However, for crack control in piles, § 15.6.7 of IRS CBC 1997 it will be clarified that actual axial load will be considered to act simultaneously.
- b) Where there is a risk of liquefaction, the lateral soil resistance of the liquefied layer will be taken as zero.
- c) Pile cap shall be designed based on § 15.8.3.1 of IRS –CBC 1997. No support from soil below pile cap shall be considered.
- d) The thickness of the pile cap shall be kept minimum 1.5 times diameter of the piles for multiple-pile group as per IRC 78.

- e) The structural design of the pile cap shall be carried out as per §10.2.2 & §15.4 and §15.8.3 of IRS CBC. Crack width shall be checked for load combination 1 as per §15.9.8.2 IRS CBC.

#### **12.4.2 Soil Structure Analysis**

When designing element forces or estimating displacements the soil stiffness and other parameters shall be assessed based on clause 5.7 of the DBR considering the design ground water table as per clause 5.5 of the DBR.

#### **12.4.3 Well Foundation & Open foundation**

Well Foundation & Open foundation shall be designed as per IRS Bridge Substructure & Foundation Code and IRC: 78.

### **13 LIST OF DESIGN CODES AND STANDARDS, APPLICABILITY**

The IRS Codes shall be followed in principle. Although main clauses have been mentioned in the DBR, the other relevant clauses as available in the IRS codes shall also be followed, whenever applicable. If provisions are not available in IRS, the order of preference shall be as follows, unless specified otherwise:

#### **For railway loading related issues:**

- i. UIC Codes
- ii. Euro Codes
- iii. Any other code, which covers railway loading.

#### **For other Design/ detailing related issues:**

- i. IS
- ii. IRC
- iii. EURO
- iv. AASHTO
- v. Any international code with approval of DMRC.

#### **13.1 IRS CODES (WITH LATEST VERSIONS, ALL AMMENDMENTS AND CORRECTION SLIPS UP TO DATE OF BIDDING)**

- IRS Bridge Rules
- IRS Concrete Bridge Code
- IRS Bridge substructure & Foundation Code
- IRS Steel Bridge Code
- IRS Fabrication Code (B1)
- IRS Welded Bridge Code
- IRS code for Earthquake resistant design of Railway Bridges 2017

### 13.2 IRC CODES (WITH LATEST VERSIONS AND ALL AMMENDMENTS UP TO DATE OF BIDDING)

- IRC: 5 Standard Specification & Code of Practice for Road Bridges - General Features of Designs
- IRC:6 Standard Specification & Code of Practice for Road Bridges- Loads and Stresses
- IRC: 18 Design Criteria for Pre-stressed Concrete Road Bridges (post Tensioned Concrete)
- IRC: 22 Specification & Code of Practice for Road Bridges, Section VI - Composite Construction for Road Bridges
- IRC: 24 Standard Specification & Code of Practices for Road Bridges, Section V- Steel Road Bridges
- IRC: 78 Standard Specification & Code of Practice for Road Bridges - Section Foundations & Sub-Structure
- IRC: 83(I) Standard Specification & Code of Practice for Road Bridges, Part-I Metallic Bearings
- IRC: 83(II) Standard Specification & Code of Practice for Road Bridges, Part-II Elastomeric Bearings
- IRC: 83 (III) Standard Specification & Code of Practice for Road Bridges, Part-III POT, POT-cum PT;TE, Pin and Metallic Guide Bearings
- IRC: 83 (IV) Standard Specification & Code of Practice for Road Bridges, Part, IV Spherical and Cylindrical Bearings.
- IRC: 112 Code of practice for Concrete Bridges
- IRC-SP-71 Guidelines for Design and Construction of Pre-cast Pre-tensioned Girders for bridges

### 13.3 IS CODES (WITH LATEST VERSIONS AND ALL AMMENDMENTS UP TO DATE OF BIDDING)

- IS: 269 Specs for Ordinary and Low Head Portland cement
- IS: 383 Specs for coarse and fine aggregates from natural sources for concrete
- IS: 432 Specs for Mild steel and medium tensile steel bars (Part 1)
- ID: 456 Plain and reinforced concrete - code of practice
- IS: 800 Code of practice for General Construction Steel
- IS: 875 Code of Practice for Design Loads Part 1, 2 3, 4& 5 (Other than Earthquake)
- IS: 1080 Design and construction of shallow foundations in soils (other than raft ring and shell)
- IS: 1343 Code of practice for Pre-stressed concrete-based essentially on CP-110
- IS: 1364 Hexagon Head Bolts, Screws & nuts of product grades A & B Part 1 (part 1 Hexagon, Head Bolts (size range M 16 to M64)

- IS: 13920 Ductile detailing of reinforced concrete structures subjected to seismic forces code of practice
- IS: 1489 Specification for Portland pozzolana cement (Fly ash based)
- IS: 1786 High strength deformed steel bars and wires for concrete reinforcement
- IS: 1893 Criteria for Earthquake Resistant Design of structures
- IS: 1904 Design and construction of foundations in soils: general requirements.
- IS: 1905 Code of practice for structural use of unreinforced masonry.
- IS: 2062 Specifications for weldable Structural steel
- IS: 2502 Code of Practice for Bending and Fixing of Bars for Concrete Reinforcement
- IS: 2911 Code of practice for Design and construction of Pile foundation Part 1 (Part I/Sec 1) Concrete Piers Section 2 Board Cast-in-situ-piles (with amendments)
- IS 2911 Code of Practice for Design & construction of Pile foundations Part 4 Load test on piles
- IS: 2950 Design and construction of raft foundations
- IS: 3935 Code of Practice for Composite Construction
- IS: 4326 Code of practice for Earthquake resistant design and construction of Buildings
- IS: 4923 Hollow steel sections for structural use -specification
- IS: 8009 Calculation of settlements of shallow foundations
- IS: 8112 Specifications for 43 grade ordinary Portland cement
- IS: 9103 Specifications of Concrete admixtures
- IS: 11384 Code of practice for Composite Construction in Structural Steel and Concrete
- IS: 12070 Code of practice for Design and construction of shallow foundation on Rocks
- IS: 12269 Specification for 53 grade ordinary Portland cement
- IS: 14268 Uncoated Stress Relieved Low relaxation Seven-ply Strands for Prestressed concrete
- IS: 14593 Design and Construction of Bored Cast-in-Situ Piles Founded on Rocks.

#### **13.4 BS CODES (WITH LATEST VERSIONS AND ALL AMMENDMENTS UP TO DATE OF BIDDING)**

- BS: 4447 Specifications for the performance of prestressing anchorage for post-tensioned concrete.
- BS: 4486 Specifications for high tensile bars used for prestressing.
- BS: 5400 Code of Practice for Design of Concrete Bridges Part 4-1990.

- BS: 8006 Code of Practice for strengthened reinforced soils and other fills-1995.
- BS: 8007 Design of Concrete structures for retaining liquids.

### **13.5 OTHERS (WITH LATEST VERSIONS AND ALL AMMENDMENTS UP TO DATE OF BIDDING)**

- UIC:776-1R Loads to consider in Railway Bridge Design
- UIC:776-3R Deformation of Bridges
- UIC: 772 Then International Union Railway Publication
- UIC: 774 - 3R Rail structure interaction
- CEB\_FIB Model Code 1990 for Concrete Structures
- The design relating to Fire safety and escape shall be in accordance with the requirements of NFPA 130 standard for fixed guide way system.
- FIP Recommendations for the Acceptance of Post-tensioned systems.
- M.O.R.T and Highways specifications.
- Euro code 0 Basis of Structural Design.
- Euro code I Actions on Structures-Part 2-Traffic Loads on Bridges.
- Euro code 2 Design of Concrete Structures- Part 1.1: General Rules and Rules for Building.
- Euro code 2 Design of Concrete Structures- Part 2, Concrete Bridges - Design and Detailing Rules.
- ACI 358: IR-92 (American Concrete Institute) for assessment of dynamic impact for transit Guide ways.
- ROSO Guidelines for carrying out RSI (Version 2.0) issued in January 2015 BS-111 version-3 issued in January 2015.

All codes listed above shall be of latest revision including all amendments & corrections.

## **14 DESIGN SOFTWARE**

Any commercial or proprietary software can be used for analysis/design provided the same is validated with manual computations or other standard software in multiple scenarios.

**OUTLINE DESIGN SPECIFICATIONS  
FOR  
CUT & COVER SECTION**

## **1 INTRODUCTION**

After the realization of the first three phases of Delhi Metro, DMRC has started the development of its 4th Phase. This report highlights the structural design basis for UG stations, cut & cover tunnel, ramp on underground section.

## **2 SCOPE OF DBR**

This Design Basis defines the structural design assumptions for Underground Station / Cut & Cover portion, as described above. The aim is to collect in a unique document for all the design input and procedures to be employed for the calculation and design of underground structures. The report gives the basis for calculations including the applicable codes and standards, the material properties, the design method, the loading to be taken into account and the considered load combinations. The present document will be used as reference for the future calculation notes and structural drawings. It should be adopted in conjunction with the Geotechnical Interpretative Report specific for each Underground structure.

## **3 CUT & COVER STRUCTURES**

### **3.1 Introduction**

This section summarizes the Civil, Structural and Geotechnical design philosophy and other related parameters for underground stations, station entrances, vent shafts, subways and cut & cover tunnel. For geotechnical design parameters, reference shall be made to Geotechnical Interpretative Report.

### **3.2 General Principles**

1. Cut-and-cover structures include UG station, station entrances/exits, vent shafts, subway, utility duct, OTE DUCT, Cut & Cover Box tunnels, Cut & Construct Open U Ramp structures linking with Elevated Ramps and the structures other than bored tunnels that are required to be constructed below ground surface.
2. The cut-and-cover structure is proposed to be a rigid box section with permanent walls as external wall support system and beam-slab & column forming the internal structural framing. The roof slab shall support the soil and vehicular LL surcharge while the passenger and plant loads are carried by the concourse slab. The track and platform loads shall be supported by the base slab. The permanent walls shall resist the lateral earth and hydrostatic pressures in addition to the LL and building surcharge (horizontal loads) from nearby road and buildings.
3. The completed stations, station entrances, vent shafts shall comply with Contract water-tightness criteria.

4. Where temporary walls are intended as part of the Permanent Works, the Contractor shall justify the feasibility and suitability of such to the Employers Representative. The durability criteria shall also be satisfied to ensure 100 years design life.
5. The Contractor shall take into account the following in the design of cut-and cover structures.
  - a. Method of construction, including temporary works and construction sequence.
  - b. Ground/structure interaction, including the effects of temporary works.
  - c. Ground pressure, shear force and bending moment distribution during construction and in the long-term.
  - d. Short- and long-term ground and groundwater response.
  - e. Other static loads changes such as; excavation, surcharge, traffic loadings and the like.
  - f. Long-term water table level changes
  - g. dynamic (such as seismic or vibratory plant) loads and displacements.
6. For the purposes of assessing ground and groundwater pressures during service stage, the cut-and cover structures shall be considered to be effectively impermeable rigid box structures subject to "at rest" ( $K_0$ ) earth pressure and "active" ( $K_a$ ) earth pressure as the case may be.
7. The Contractor shall design to minimize the effects (such as movement, distortion of the ground and the like) on all Existing Building Structure (EBS) that may be affected by the Works. Where necessary the Contractor shall provide additional support for these EBS. Building damage assessment reports along the zone of construction shall be prepared and the type of strengthening required may be decided based on category of building.

### **3.3 Design Principles**

1. The design of all cut-and-cover structures shall take into account, but not be limited to the following:
  - a. The variation in ground conditions along the alignment.
  - b. The variation in engineering properties of soil or rock within the influence of the proposed works.
  - c. All dewatering and groundwater cut-off systems required to maintain dry and stable conditions within all excavations required for these Works.
  - d. Any ground treatment before, during or after construction of the Works (e.g. groundwater recharge) which is required to stabilise the ground and EBS in order to minimise adjacent ground and EBS movement and distortion.
  - e. Methods by which the completed structure shall be secured against flotation. Any

- temporary dewatering system shall not be turned off till the structure is safe against leakage or flotation when the ground water returns to the design levels.
- f. Differential groundwater pressures due to inside and outside water table
  - g. Methods of waterproofing the completed structure.
  - h. Drawdown of the groundwater levels outside the UG station and cut and cover tunnel walls shall be limited to not more than 2 metres from the existing average groundwater level in the zone of construction. Recharging pits shall be provided in case there is a danger of reduction in water table outside area of construction. This is necessary to prevent settlement of ground outside area of construction. In general, groundwater levels interior to construction excavations shall not be depressed more than 1.0m below final base slab level.
  - i. The magnitude of ground and EBS movements and distortions, and changes in loading conditions on these EBS that might be expected as a result of the works and how these will be mitigated so as to comply with any imposed constraints or so as to minimise disturbance to these EBS.
  - j. Any difficulties that the Contractor's intended plant/machinery/methods might meet with in respect of access, clearances, working space and obstruction to excavation.
  - k. Maintenance of traffic flows along roads including access to adjoining properties and roads.
  - l. Noise levels produced during construction.
  - m. Control of heave, swell, piping and instability of the excavations.
  - n. The effects of vibration and vibration induced movements – e.g. earthquake.
2. The following methods of construction shall be used either individually or in combination depending upon the particular requirements of the location, size and type of structure.
- a. Diaphragm Walls - Particular attention shall be paid to the D wall and panel alignment, the stability of excavation, the design mix and condition of the slurry, placement of the reinforcement cage, methods for forming and locating box-outs, waterproofing of the vertical panel joints, placement of concrete, and the overall integrity and water-tightness of the formed wall.
  - b. Secant Piles/Sheet Piles/Soldier Piles and Horizontal Planks – Particular attention shall be paid to the construction/installation of the piles and ground support systems to ensure their integrity and water-tightness and to provide adequate support to the

ground during excavation.

3. Diaphragm walling is the preferred support method for the TBM Shafts, UG station, construction close to sensitive existing structures, Cut & Cover Box tunnel excavations at large to medium depths close to existing structures, cross over structures, etc
4. Soldier Pile wall/ Bored Pile wall methods of support may be used for the other medium excavations such Cut & Cover tunnel, entrances/exits, utilities and services. In case of high underground water table, soldier pile system with horizontal plans is not allowed.
5. Sheet Pile wall methods of support may be used for the other shallow excavations such as open U Ramp, shafts utilities and services.

### **3.4 Excavation Support**

#### **3.4.1 General**

- a. The Contractor shall prepare and submit a detailed Design Report including calculations, schedules and drawings for each proposed excavation support wall construction, prior to the commencement of any such works. This Design Report shall take into account but not be limited to the following:
  - i) Earth pressure.
  - ii) Hydrostatic pressure.
  - iii) Deck load
  - iv) Surcharge loads.
  - v) Seismic and/or vibratory loads
  - vi) Support types and arrangement.
  - vii) Temperature loads
  - viii) Any other incidental/accidental load.
  - ix) Construction/deconstruction sequence.
  - x) Calculated ground and adjacent EBS movements and distortions.
  - xi) Calculated fluctuations in groundwater levels both within and outside of the excavation and support walls.
  - xii) Calculated changes in EBS loading conditions.
  - xiii) For Deep Excavation in rocky strata, Rock bolt and Shotcrete to be used.

#### **3.4.2 Method Statement**

- a. The Contractor shall prepare a Method Statement giving the full details of materials, plant and operations involved in the construction of excavation support walls. This Method Statement shall be incorporated into the Design Report submission for the Employers Representatives notice and shall include but not be limited to the following details:
  - i) Formation of the joints between panels and installation of water stops.
  - ii) Method of producing the workable concrete.
  - iii) Methods of handling within the excavations and disposing of groundwater outside of the excavations.
  - iv) Sequence of excavation and concreting of panels.

- v) Methods of instrumenting, monitoring and reporting of the performance of all adjacent EBS that may be affected by the works.
  - vi) Type and construction of permanent lining wall.
  - vii) Emergency procedures to be implemented in the event that monitoring indicates tolerances associated with the excavation support wall may be exceeded.
- b. Where temporary ground support is to be provided using bentonite slurry, the following additional information shall be provided in the Method Statement for these works.
- i) Mixing, transporting and placing equipment for the bentonite slurry.
  - ii) Method of disposal of contaminated bentonite slurry.
  - iii) Type, source, chemical and physical properties of the bentonite to be used.
  - iv) Stability, dimensions and details of guide walls.
  - v) Cleaning and re-use of the bentonite slurry.
  - vi) Calculations to show that the density of the bentonite and lowest head of slurry are sufficient to maintain the stability of the trench excavated for the support wall, in the ground conditions envisaged, to its full depth.

### **3.5 Design Life and Serviceability**

#### **3.5.1 General**

The design life of a structure or component is that period for which the structural item is required to fulfil its intended function when maintained in accordance with agreed procedures to meet a required level of performance. The definition of a design life for a structure or component does not necessarily mean that the structure will no longer be fit for its intended purpose at the end of that period. Neither will it be expected to necessarily continue to be serviceable for that length of time without adequate maintenance to mitigate the demands of degradation.

#### **3.5.2 Civil Engineering Structures**

1. The design life of all civil engineering structures shall be a minimum of 100 years unless otherwise specified or agreed upon.
2. Adequate measures shall be taken to ensure a minimum of 100 years serviceability of civil structures by producing durable concrete structures. For achieving this suitable property enhancers / blending materials conforming to relevant BIS codes (or more stringent International Standards/Codes wherever required) may be used as deemed appropriate and subject to Notice of No Objection from the Engineer.
3. The design life of the above ground building structures including ancillary buildings, utility support, structures and vent shafts etc. shall also be 50 years.
4. The design life of non-structural elements shall be 50 years.
5. Durability approach and assessment report (DAAR) to ensure service life of structures shall be submitted and to be got approved before start of work on site.

### 3.5.3 Road pavement

The design life of all pavements shall conform to the requirement of relevant codes of IRC and MORTH.

### 3.5.4 Serviceability of Civil and Building Works

1. Paint systems for steelwork, wherever permitted by the Engineer, shall ensure a minimum life of 5 years before full maintenance painting is required.
2. The corrosion protection of non-structural steel items shall be appropriate to the accessibility of the item for inspection and maintenance.

### 3.6 Units

The main units used for design will be: [t], [m], [mm], [kN], [kN/m<sup>2</sup>], [MPa], [°C], [rad]

### 3.7 Material Parameters

#### 3.7.1 Cement

Cement shall be as defined in Outline Construction Specifications for Phase-IV Civil Works.

#### 3.7.2 Concrete

Concrete shall be as defined in Outline Construction Specifications for Phase-IV Civil Works.

The characteristic strengths (fck) and the corresponding mechanical characteristics necessary for design as per requirements for 100 years of design life of structures are indicated in Table here below: -

- A Characteristics of main construction Materials (structural elements in contact with non-aggressive soil of Delhi)

S. No.	Structural Components	Minimum Grade of concrete (cube)
1	Inner slabs, beams & columns	M35
2	Outer slabs	M35
3	Outer cast-in-situ walls against form work	M35
4	Diaphragm walls	M35
5	Tension Pile, barrettes, compression piles	M35
6	Platform slab, UPE duct, OTE duct, vent shafts etc	M35

- B Characteristics of main construction Materials (structural elements in contact with Drain Water , chemically aggressive environment and soils)

<b>S. No.</b>	<b>Structural Components</b>	<b>Minimum Grade of concrete (cube)</b>
1	Outer slabs	M45
2	Outer cast-in-situ walls against form work	M45
3	Diaphragm walls	M45
4	Tension Pile	M45

### 3.7.3 Cover Requirements for 100 years durability of structures

- A For Underground structural elements in contact with non-aggressive soil of Delhi

<b>S. No.</b>	<b>Structural Components</b>	<b>Nominal Cover/clear cover to any reinf. (mm)</b>
1	Inner slabs, beams & columns	50
2	Outer slabs at roof	50
3	Outer Base slabs	75
4	Outer cast-in-situ walls against form work	50
5	Diaphragm walls	75
6	Tension Pile, barrettes, compression piles	80
7	Platform slabs, internal RCC walls, vent shaft walls, staircase slabs, UPE and OTE ducts	35

- B For Underground structural elements in contact with Drain water, aggressive soil and environment

<b>S. No.</b>	<b>Structural Components</b>	<b>Nominal Cover/clear cover to outermost reinf. (mm)</b>
1	Outer slabs	65
2	Outer cast-in-situ walls against form work	65
3	Diaphragm walls	90
4	Tension Pile, barrettes, compression piles	95

### 3.7.4 Density

- 25 kN/m<sup>3</sup> for reinforced concrete (IS:875 Part-1 Table-1 item 22 value rationalized)
- 23 kN/m<sup>3</sup> for plain concrete (IS:875 Part-1 Table-1 item 20)
- Actual density to be validated as per actual mix design

### 3.7.5 Poisson's Ratio

- Poisson's ratio for all concrete: 0.15

### 3.7.6 Thermal Expansion Coefficient

- As per cl. 6.2.6 of IS: 456

### 3.7.7 Young's Modulus

Instantaneous modulus (E) is taken as per clause 6.2.3.1 of IS 456:2000  
 $E = 5000 (f_{ck})^{0.5}$

Where,  $f_{ck}$  is the Characteristic Compressive Strength of 150mm Cube at 28 days.

### 3.7.8 Modular Ratio

Modular ratio for all concrete grades shall be taken as per Annex B of IS:456.

Modular ratio, for cracked section  $m = E_s/E_{eff}$

Where,

$E_s$  = Steel Modulus  
 $E_{eff}$  = Eff. Modulus of Concrete ( $E_{eff} = E_c / (1+\theta)$ )

### 3.7.9 Reinforcement

Only thermo-mechanically treated reinforcement bars of grade Fe500D with minimum total elongation of 14.5% conforming to IS 1786 shall be adopted. However, for design of shear stirrups strength parameters of Fe415 only shall be considered.

The material properties shall be as follows:

Young's Modulus [Mpa]	Yield Stress [Mpa]	Diameters [mm]	Density [kN/m <sup>3</sup> ]	Poisson's Ratio	Thermal Coefficient per °C
200,000	415 for Fe415 500 for Fe 500 D	8, 10, 12, 16, 20, 25, 28, 32, 36, 40	78.5	0.3	$12 \times 10^{-6}$

### 3.7.10 Structural Steel: General

- (1) Design of Structural steelwork shall comply with IS: 800.

- (2) Two types of structural steel to be used and shall comply with the following standards:
  - a) IS: 4923 "Hollow steel sections for structural use with  $Y_{st}$  310".
  - b) IS: 2062 "Steel for General Structural Purposes (Grade Designation E250 BR).
- (3) Hollow steel sections shall be square (SHS) or rectangular (RHS). Other traditional rolled sections like plates, angles, channels, joists can also be used where required.
- (4) The connections within the steel structure shall be designed as direct welded members with or without gusset plates. The minimum thickness of metal for SHS/RHS sections for main chord members as well as bracings shall be 4 millimetres as applicable for steel tubes in cl. 6.3 of IS: 806.
- (5) IS:800-2007 shall be followed and limit state method of design shall be adopted for steel structures.

Material Properties shall be as follows:

Steel Type	Young's Modulus	Tensile Strength	Yield Strength	Density [kN/m <sup>3</sup> ]	Poisson's Ratio	Thermal Expansion Coefficient
For Hollow Steel Sections (Conforming to IS: 4923)	200000 Mpa	450 Mpa	310 Mpa	78.5	0.30	1.2x10 <sup>-5</sup> Per °C
Structural Steel (Conforming to IS: 2062)		410 Mpa	250 Mpa (for t < 20mm), 240MPa (for 20mm < t < 40 mm), 230MPa (for t > 40mm)			

### 3.8 Durability Criteria

In carrying out structural designs it shall be ensured that both the serviceability and ultimate limit states have been checked in accordance with the applicable Standards and Codes.

To achieve durability, the design shall take into account the prevailing ground and groundwater conditions and those predicted to occur at the site within the design life of the Works.

Water permeability in concrete shall not be more than 10 millimetres (at the concrete age of 28 days) according to DIN 1048 and RCPT value (ability to resist chloride ion penetration) shall not exceed 1000 coulombs at the concrete age of 28 days according to ASTM C-1202.

For all other durability requirements refer Outline Construction Specifications for Phase-IV Civil Works, Delhi Metro.

### **3.8.1 Fire Resistance Period**

All structures shall be designed for fire protection as specified by the applicable standards and codes. Materials specified for the Works shall be non-combustible and nor emit toxic fumes when subject to heat or fire, except where permitted under the Contract. In all cases where there is significant fire risk, materials shall be self-extinguishing, low flammability, low smoke and low toxicity. All the main elements of the station structures (Roof Slab, Concourse Slab, Base Slab, Outer Wall, Columns & any load bearing RCC Walls, ASS -TSS room RCC walls) and including firemen staircase & Public fire escape underground structures shall be designed for a minimum fire resistance period of 4 hours. All other element like Platform slab, vent shafts, UPE Walls, OTE Ducts, Stub Columns, other non load bearing RCC walls etc. shall be designed for 2-hour fire rating.

A nominal cover shall be provided for four hours or two hours of fire resistance respectively as per IS and NBC codes.

### **3.8.2 Crack Width**

All structural concrete elements shall be designed to prevent excessive cracking due to flexure, early age thermal and shrinkage. The maximum crack widths shall be as specified below.

#### **a) Flexural Cracking**

Formulae for Flexural crack width shall be as mentioned in Annex F of IS 456:2000. The limits specified shall apply irrespective of whether any additional protection, such as waterproofing membrane are provided to the members at the exposed face of the structure.

#### **b) Early age Thermal and Shrinkage Cracking**

- (1) Suitable reinforcement shall be designed to prevent early age thermal and shrinkage cracking for walls and slabs more than 250 millimetres thick and subjected to internal and external restraints during construction. The thermal and shrinkage strains due to early age temperature differences and shrinkage shall be accounted for in the design of reinforcement for cracking.
- (2) It is preferred that smaller diameter bars in any direction are placed at closer intervals to prevent early age thermal and shrinkage cracks. The limits specified below shall be imposed. Guidance can be sought from CIRIA C660-latest version on Early Age Thermal Control of Concrete in this matter.

- (3) Minimum reinforcement shall be higher of:
- 0.125% of cross-sectional area of structural member on each face in each direction.
  - Reinforcement required as per Early Age Thermal (EAT) control of concrete.
- c) For Underground structural elements in contact with non-aggressive soil of Delhi

S. No.	Structural Components	Min. Cover for crack width calculation Cmin*	
		Concrete Grade M35	Concrete Grade M40 and above
1	Inner slabs, beams & columns	45	40
2	Outer slabs	45	40
3	Outer cast-in-situ walls against form work	45	40
4	Diaphragm walls, barrettes, Tension/compression piles	45	40

- d) For Underground structural elements in contact with Drain water, aggressive soils or environment

S. No.	Structural Components	Min. Cover for crack width Cmin*	
		Concrete Grade M35	Concrete Grade M40 and above
1	Outer slabs	45	40
2	Outer cast-in-situ walls against form work	45	40
3	Diaphragm walls, barrettes, Tension/compression piles	45	40

\*The cover shall be considered as defined in sketches below.

However, as per durability requirements of 100 years for design life of underground structures and minimum concrete cover, BS:8500-1-2006 has also to be followed for the exposure condition for the different members as under:

- Corrosion by carbonation criteria**

S. No.	Structural Components	Exposure Class
1	All Structural members (outer/Inner)	XC3

- Corrosion by Carbonation criteria with hydraulic gradient more than 5 meter**

S. No.	Structural Components	Exposure Class
1	All Outer structural members	XC2 / AC-2/DC-2 (FND2)

The parameters such as Grade of Concrete, Concrete cover etc. shall be provided as per worst of both as mentioned above.

- **Corrosion by chloride criteria for members in contact with aggressive soil/ Nallah etc.**

Where soil is aggressive in addition to above criteria (given in A & B), following criteria shall also be ensured:

S. No.	Structural Components	Exposure Class
1	All Outer structural members	XD1

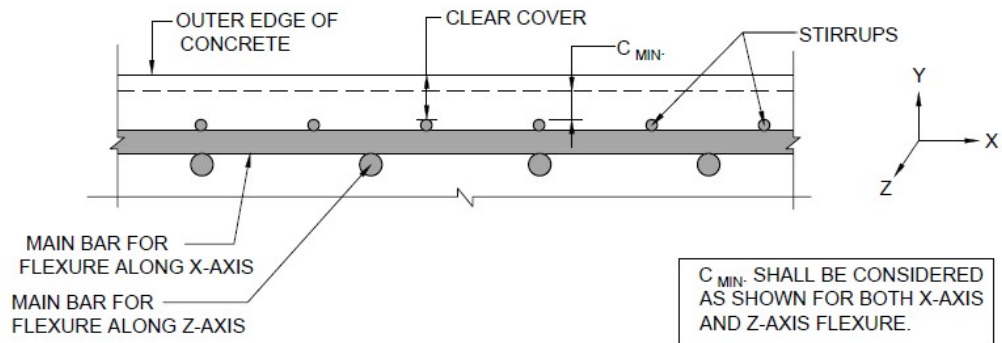
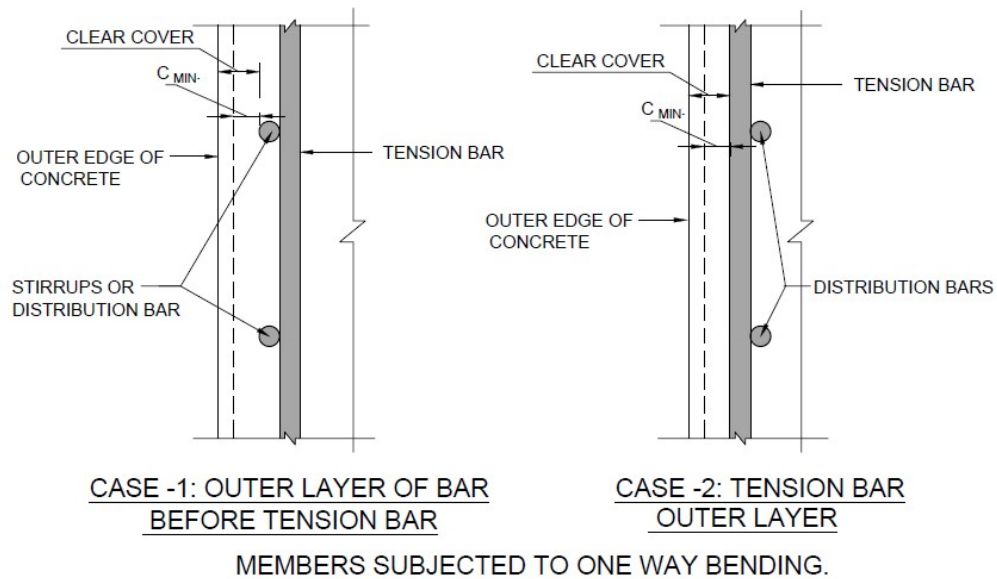

MEMBERS SUBJECTED TO TWO WAY BENDING.

e) **Permissible crack width**

1. For Members in Contact with Soil: -

- 0.2mm for soil face
- 0.3 mm for inner face

2. For Members not in Contact with Soil: -
  - 0.3 mm
3. For Water Tanks: -
  - 0.2 mm

## 4 LOADS AND REQUIREMENTS

### 4.1 General

Unless specified otherwise the design of concrete and steel elements shall conform to IS 456 and IS 800, respectively.

### 4.2 Nominal Loads

For the purpose of computing stresses and deformations, the following minimum load types and consequential effects shall be taken into account as applicable.

Dead loads (including notional loads)	DL
Superimposed Dead loads	SIDL
Imposed (Live) loads	LL
Railway loads	RL
Fatigue	FG
Dynamic	DY
Derailment	DR
Wind Loads	WL
Temperature loads	TE
Seismic Loads	EQ
Construction/Erection	ER
Shrinkage	SH
Creep	CP
Movement/ Distortion	MD
Earth Pressure	EP
Surcharge	SR
Hydrostatic	WP
Accidental	AC
Redundancy	R

### 4.3 Design Loads

Design shall include all of the following loads:

#### 4.3.1 Dead Loads

Self-weight of the materials shall be calculated in accordance with IS 875:1987 Part 1.

#### 4.3.2 Superimposed Dead Loads and Imposed (Live) Load

The minimum distributed and concentrated loads shall be in accordance with following Table, and Contract specifications.

##### Superimposed Dead Loads (SIDL) & Imposed (Live) Loads

Description	Superimposed Dead Load			Imposed Load	
	Finishes (kN/m <sup>2</sup> )	Partitions (kN/m <sup>2</sup> )	Ceiling & Services (kN/m <sup>2</sup> )	U.D.L. (kN/m <sup>2</sup> )	Concentrate d Load (Note 2 & 3)
<b>Station</b>					
Concourse Area	2.4(Note 5)	1.0(Note 6)	1.0(Note 6)	5.0(Note 1)	15.0
Platform Area	2.4(Note 5)	1.0(Note 6)	-	5.0(Note 1)	15.0
Track	(Note 10)			Refer Section 3.3.3	
Stairs and Landings	1.2(Note 4)	-	1.0(Note 6)	5.0(Note 1)	15.0
General Plant Rooms, Pump Room	2.4(Note 5)	-	1.0(Note 6)	7.5(Note 7)	22.5
General Office	2.4(Note 5)	1.0(Note 6)	1.0(Note 6)	2.5	7.5
Staff Rooms	2.4(Note 5)	-	1.0(Note 6)	2.5	7.5
Toilets, changing Room	2.4(Note 5)	1.0(Note 6)	1.0(Note 6)	2.5	7.5
Store	2.4(Note 5)	-	1.0(Note 6)	5.0	15.0
Water Tank, Fire Tank	2.4(Note 5)	-	-	20.0/ Water Height+0.3 m	-
Chiller Rooms	2.4(Note 5)	-	1.0(Note 6)	10.0(Note 7)	(Note 7)
Transformer Rooms, Sub stn	2.4(Note 5)	-	1.0(Note 6)	10.0/15.0/20.0( Note 7)	(Note 7)
Switch Gear Plant Room	2.4(Note 5)	-	1.0(Note 6)	7.5 (Note 7)	10.0
Roof Slab	-	-	1.0(Note 6)	Soil Load+ 20(Note 9)	-

##### Notes:

1. Stairs and landings to be designed for the same load as the floors to which they give access with a minimum of 2.5 kN/m<sup>2</sup> and a maximum of 10 kN/m<sup>2</sup> and public area staircase with minimum 5 kN/m<sup>2</sup>.

2. Concentrated loads act on a square of 300 mm each side.
3. As specified or wall loads in accordance with layout in architectural plan, whichever is greater.
4. All loads are unfactored.
5. Minimum of 100 mm thick screed on top, unit weight of  $24 \text{ kN/m}^3$ .
6. As specified above or the imposed load from services fixed to the underside of floor whichever is greater.
7. The design loads shall be actual plant/equipment loads or the ones specified above, whichever is maximum. For seismic design plate/machinery loading shall be considered as Super Imposed Dead Load.
8. Backfill / Earth Load Shall be calculated for the available soil depth for a unit weight of soil of  $20 \text{ kN/m}^3$ .
9. Live Load surcharge shall be minimum as  $20 \text{ kN/m}^2$  at ground level (fill depth greater than 1.3m) or from actual load dispersion in case it gets higher than  $20 \text{ kN/m}^2$  for the areas under roads etc.
10. The loads due to Track :
  - a) Track work - UIC rails and other fittings and accessories.
  - b) Track bed - RCC blocks or concrete pour or precast slabs in RCC with inserts and fittings in case of unballasted track (450 to 600 mm thick). Other loads -: as per Indian Railway Standards (IRS) and Bureau of Indian Standards (BIS)
11. Construction Live Load (on c/c box tunnel & station box):  $10 \text{ kPa}$  on concourse and  $20 \text{ kPa}$  on roof level with no finishes.
12. allowance and loads from temporary deck (dead load+ live load) shall be as per actual

### 4.3.3 Railway Loads

#### A Vertical Train Live Load

The Train Live Load will have the following axle configuration

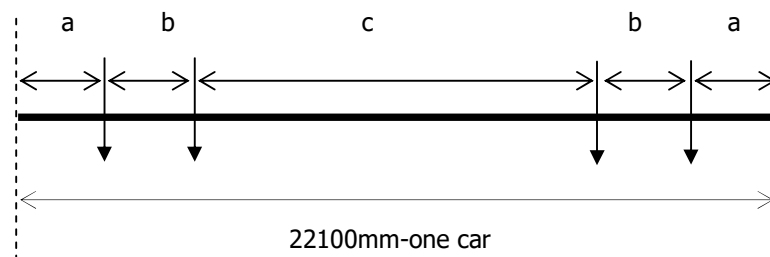

All axle loads = 17 tons

Maximum number of successive cars = 6

**Configuration (alternative -1)**

$$a = 2250 \text{ mm}$$

$$b = 2500 \text{ mm}$$

$$c = 12600 \text{ mm} \quad (2a+2b+c - 22100 \text{ mm})$$

**Configuration (alternative - 2)**

$$a = 2605 \text{ mm}$$

$$b = 2290 \text{ mm}$$

$$c = 12310 \text{ mm} \quad (2a+2b+c = 22100 \text{ mm})$$

Maximum number of axles shall be loaded on the station to arrive at maximum longitudinal force, max shear and max BM.

\* Details shown above are indicative only. Actual details of the Rolling stock and actual axle load to be obtained from DMRC.

**B Horizontal Train Live Load**

- Braking load is taken as 18% of the unfactored vertical loads.
- Traction load is taken as 20% of the unfactored vertical loads.

**C Footpath Live Load**

Footpath live load shall be adopted as 5.0 kN/m<sup>2</sup>.

**D Derailment Loads**

The Structural elements within 10m of the center line of track, which are at risk from collision by railway vehicles, shall be designed for the following collision loading. Collision loads shall be considered at ultimate limit state only:

- i. For Station platform edges a nominal load of 1000kN acting horizontally and normal to the platform slab edge over a length of 2.2m, shall be considered.
- ii. For all structural elements (columns in cross over structure) other than platform edges a nominal point load of 1250kN acting horizontally in any direction at the top of the element level, or 1.2m above the adjacent rail level, whichever is less, shall be considered. Where the soffit of the structural element occurs between 1.2m and 4.0m above adjacent rail level, the load shall be applied at soffit level.

**E Vehicle Collision Load**

The vehicle collision load due to highway loading on Retaining wall/ramp shall be considered as per IRC-6 Clause no. 222.

### 5.3.4 Wind Load

Wind Loads (longitudinal & transverse) shall be calculated as stated in IS 875: Part 3-2015.

Wind loads will be calculated in accordance with IS 875: Part 3-2015.

Design wind speed $V_z$	=	$V_b * K_1 * K_2 * K_3 * K_4$
$V_b$ (basic wind speed)	=	50 m / sec (As per NBC)
$K_1$ (risk coefficient)	=	1.07 (for 100 years mean probable design life), Table 1, pg.-7
$K_2$	=	as per table2, pg-8 based on terrain category and structure height
$K_3$ (Topography factor)	=	1.0, as per Cl.6.3.3.1, page-8
$K_4$	=	1.0 for Non-cyclonic zone as per Cl.6.3.4, pg.-8

Based on the above, Design wind pressure at height  $z$ ,  $(P_z) = 0.6 \times V_z \times V_z$  Cl. 7.2, pg.-9

Design wind pressure,  $P_d = P_z * K_d * K_a * K_c$  = wind directionality factor, pg.9 / 10

$K_d$  = wind directionality factor, page 9 / 10 of IS: 875-3-2015 = 0.9 for buildings

$K_a$  = area averaging factor, pg.9/10 = 0.8 Table 4 (for contributory area > 100 m<sup>2</sup>)

$K_c$  = combination factor, pg. 9/10 = 0.9 Cl. 7.3.3.13 of IS: 875-2015, Page 16

### 4.3.5 Temperature

For underground structure temperature shall not be used.

For above ground structure:

The loads shall be considered as per Clause-2.6 of IRS-Bridge Rules and Clause-215 of IRC: 6.

Temperature variation of + 35°C will be considered details of which are given below

Maximum Temperature considered as per Annex. F of IRC 6:2017: +47.8°C

Minimum Temperature considered as per Annex. F of IRC 6:2017: -0.4°C

Temperature variation as per clause 215.2 of IRC 6 will be  $= (47.8 - (-0.4)) / 2 + 10 = +34.1^\circ\text{C}$  say 35°C.

### 4.3.6 Seismic Loads

#### A General

Seismic effects shall be considered on all structures, including underground structures. Evaluation of seismic loads shall conform to the IS 1893 or to other relevant seismic standards or references where the Indian Standards are either not applicable or do not provide sufficient guidance. Alternatively, the structural loads can be directly evaluated using a dynamic lateral force (response-spectra) approach. The structure is required to be evaluated as an 'important service and community building' for the purpose of 'functional use' as stated in IS 1893.

The effects of load changes and deformation as a result of soil behaviour (e.g., liquefaction) shall be allowed for in the assessment and design.

## **B Seismic design for above-ground structures**

Earthquake design shall follow the seismic requirements of IS 1893 and the ductile detailing of reinforced concrete structure shall comply with IS 13920 & IS 4326.

The design base shear shall be calculated based on recommendation given in IS: 1893. The total design lateral force or design seismic base shear ( $V_B$ ) along any principal direction shall be determined by the following expression:

$$V_B = A_h W$$

Where:

$A_h$  : Design horizontal acceleration spectrum value, using the fundamental natural period  $T_a$  calculated according to clause 7.6.1 of IS 1893-2016(Part 1) in the considered direction of vibration, and;

$W$  : Seismic weight of the building calculated according to clause 7.4 of IS1893-2016 Part 1.

The design horizontal seismic coefficient  $A_h$  for a structure shall be determined by the following expression:

$$A_h = \frac{Z \times I \times S_a}{2 \times R \times g}$$

Where,

$Z$  : Zone factor. The project site falls within Zone IV. Zone factor ( $Z$ ) of 0.24 shall be taken as per IS 1893-2016 (Part 1).

$I$  : Importance factor shall be taken as 1.5.

$R$  : Response reduction factor shall be as per Table 9 of IS 1893,

$S_a/g$  : Average response acceleration coefficient for rock or soil sites as given by Fig. 2 and clause 6.4.2 of IS 1893 based on appropriate natural periods ( $T_a$ ) and damping of the structure.

Damping for the concrete structure shall be assumed as 5%. Based on type of foundations provided for the structure and soil strata type, the appropriate spectral coefficient shall be selected from Fig. 2 of IS 1893-2016 Part 1.

The vertical seismic coefficient will be taken as per clause 6.4.6 of IS 1893-2016 Part 1.

## **C Seismic design for underground structures**

i) General Solutions for Retaining Walls

Wood ("Earthquake Induced Soil Pressures on Structures") proposed elastic dynamic solutions for above ground ring degrees of flexibility. Based in this work it has been shown that for very flexible walls where the deflection exceeds approximately 0.5 % of the height of the wall the solution of dynamic pressures tends towards those suggested by Mononobe and Okabe which were based on the assumption that a full active wedge develops behind the wall. For buried structures it is unlikely that such an active wedge will form and it is therefore recommended that solutions based on rigid retaining walls as developed by Wood are used. The Bulletin of The New Zealand National Society for Earthquake Engineering (Vol. 13, No. 3) recommends that for buried structures with depths of fill less than or equal to the depth of the tunnel that the seismic load increment be calculated based on the pressure distributions shown in Fig below. The dynamic increment should be added to static earth pressure loads based on at-rest soil pressures in addition to water pressures and other imposed loads using appropriate load combinations.

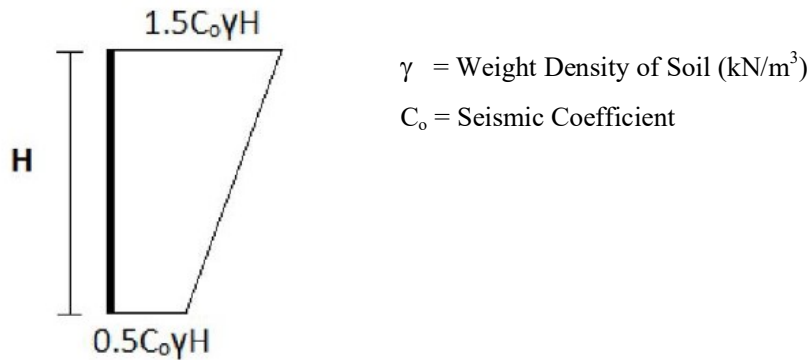

Elastic Dynamic Earth Pressure Increment for Rigid Retaining Walls

#### ii) Application to Buried Structures

For seismic design of underground structures, the following method may be adopted, in accordance with "Hashash, Y. M. A.; Hook, J. J.; Schmidt, B.; Yao, J.i-C. (2001)"Seismic Design and Analysis of Underground Structures", *Tunnel & Underground Space Technology* 16, pp. 247-293".

#### **a) Load Combinations for ODE (Operating Design Earthquake):**

**PGA for ODE: 0.18 g**

#### **b) Load Combinations for MDE (Maximum Design Earthquake):**

**PGA for MDE: 0.36 g**

Note:-

1. Moment Magnitude ( $M_w$ ) of 7 and Source to site distance of 50-100 km shall be consider calculating ratio of peak ground velocity to peak ground acceleration. Value for Magnitude ( $M_w$ )

- of 7 must be calculated by Interpolation between 6.5 and 7.5 magnitude (Mw) from Hashash et. al, 2001.
- The shear wave velocity shall be co-related with N-Value in case of soil as per below correlation. The shear wave velocity for rock shall be calculated based on modulus of elasticity and Poisson's ratio as per below empirical formula. These values of soil parameters shall be considered from the approved GIR.

**Shear Wave Velocity for Soil:**

The following correlation shall be considered for calculation of shear wave velocity upto SPT (corrected) of 40. The shear wave velocity shall be calculated based on weighted average value of SPT ignoring top 3 m depth from GL.

$$V_s = 79 \times N^{0.434} \text{ m/s (for sand) [C Hanumantha Rao & G V Ramana, 2008]}$$

$$V_s = 86 \times N^{0.42} \text{ m/s (for silty sand/sandy silt) [C Hanumantha Rao & G V Ramana, 2008]}$$

$$V_s = 94.4 \times N^{0.379} \text{ m/s (for clayey soil) [B K Maheshwari et. al, 2016]}$$

The above co-relation are considered from the detailed study and published as follows:

- Hanumantharao, C.; Ramana, G. V. (2008) "Dynamic soil properties for microzonation of Delhi, India" *J. Earth Syst. Sci.* 117, S2, pp. 719-730,
- Kirar, B.; Maheshwari, B.K.; and Muley, P. (2016). "Correlation between Shear Wave Velocity (Vs) and SPT resistance (N) for Roorkee region." *Int., J., of Geosynth., and Ground Eng.*, pp. 1-11

**Shear Wave Velocity for Rock** (Reference: Technical Manual for Design and Construction of Road Tunnels — Civil Elements):

Effective shear modulus,  $G_m$  = Shear modulus, G (Assuming isotropic rock)

$$= E/2(1+v)$$

Effective shear wave propagation velocity,  $C_{se} = (G_m/\rho)^{1/2}$

Where  $\rho$  = Mass density of ground, E = Elastic Modulus of rock and v = Poisson's ratio

The design shear wave velocity shall be considered as weighted average values of different layers of rocks.

### 4.3.7 Construction/Erection

The weight of all permanent and temporary materials together with all other forces and effects which can operate on any part of structure during construction shall be taken into account. Allowances shall be made in the permanent design for "locked-in" stresses caused in any member during construction.

### 4.3.8 Shrinkage and Creep

Provisions shall be made for the effects of shrinkage and creep within concrete structures. This includes interface shear transfer mechanisms as a result of differential creep and residual shrinkage effects from staged casting of concrete elements. The shrinkage and creep strains shall be included in calculation of long term deflection of all structural elements in accordance with Annexure C of IS 456-2000 and the limits specified in clause 23.2 shall be applied.

The above ground structures shall be designed for shrinkage strain as below:

Shrinkage strain shall be evaluated as Cl. 6.2.4 of IS: 456 for plain and RCC structures and Cl. 6.2.4 of IS: 1343 for prestressed concrete structures.

Creep strain shall be evaluated as Cl. 6.2.5 of IS: 456 for plain and RCC structures and Cl. 6.2.5 of IS: 1343 for prestressed concrete structures.

### 4.3.9 Differential Settlement

Consideration of the forces resulting from differential settlement shall be made where the nature of the chosen foundation system and the ground conditions indicate that such a condition may arise but not more than:

- 10 mm Long Term Settlement
- 5 mm Short Term Settlement

### 4.3.10 Earth Pressure

Underground vertical elements that are in direct contact with the ground shall be designed as permanent retaining walls to resist the lateral earth pressure. The earth pressure coefficients shall be calculated based on geotechnical investigations.

### 4.3.11 Surcharge

(a) Live Load: A vehicular live load surcharge of 24KPa (lateral & vertical) for on road stations shall be adopted for the design of all underground structures under live load category. Actual calculation shall be done for vertical live load surcharge on roof slab, in case of soil cover less than 1.5m. For heavy plants and equipment such as ancillary building, the actual loading shall be determined individually and considered in the design of station.

(b) Building Surcharge: For existing buildings and other existing structures occupying areas around the excavation, detailed assessments based on building and foundation type, and loading are to be carried out to determine the applied loads and other impacts of such building loads on the proposed structures, for future buildings or planned infrastructure around UG station, the appropriate authorities and Employers Representative shall be consulted for details.

However, in general the minimum building load surcharge of  $60 \text{ kN/m}^2$  shall be adopted. In case, the actual building load surcharge exceeds  $60 \text{ kN/m}^2$  the actual value is to be considered.

#### **4.3.12 Groundwater**

Loads due to water pressure shall be calculated using a unit weight of  $10 \text{ kN/m}^3$ .

The Ground water table (Base value) shall be considered as maximum (in terms of RL) of Ground water table from

- a) data published by Central Ground water board (CGWB) nearest bore holes,
- (b) Ground water table reported in Geotechnical report provided by DMRC in tender documents,
- (c) Ground water table reported in Geotechnical report provided by Design & Build contractor.

The design Ground water table shall be taken as 2.0m higher than the Base value for evaluation of effects for design purposes during service stage.

The level of water table for Construction stage analysis shall be adopted as Highest Record Level (HRL) at site.

Should liquefaction of soils be a potential risk then the design water table level for permanent structures shall include layers affected by liquefaction if this is above the design groundwater levels. The effects of temporary drawdown, seepage and base heave effects shall be considered in design of the temporary works and catered for in the permanent works if there is a "locked-in" effect from carry-over forces. The extent of the temporary walls shall be sufficient to mitigate the effects of such loads during construction. The effects of flotation loads shall be allowed for in the design both in the temporary and permanent design stages. The proposed structures (primarily the stations) may act as obstructions to groundwater movement.

#### **4.3.13 Accidental**

The design shall allow for a minimum impact loading of 50 kN acting at any position and at any direction on temporary works or on partially completed permanent works.

#### **4.3.14 Air Pressure**

From Trains entering and leaving stations

- 1.5 kPa at tunnel entrance and through platform
- 1.5 kPa in tunnel ventilation shafts and platforms
- 0.5 kPa elsewhere

#### **4.3.15 One Strut Failure**

The temporary structures shall be checked for the effects of a 'One-Strut failure' condition. A condition of Single Strut failing at any location when all strut and Wallers are installed, shall be evaluated in Ultimate limit state condition with Load factor of 1.05

#### **4.4 Loading Combinations**

Each component of the structure shall be designed and checked for all possible combinations of applied loads and forces. The load factors and load combinations for ultimate and serviceability limit states are specified as annexure – A.

Same load factors stated above for design of permanent works should be considered for the design of temporary works also.

Notes: -

1. Structural steel design load combinations and partial factors of safety for the design of structural steelwork are to be in accordance with IS 800 - Code of Practice for the Structural Use of Steel Work
2. Earthquake loads are reversible.
3. Creep, shrinkage, temperature and differential settlement are not considered in combination with the lateral loads at ultimate limit state.

For those structural members which are load bearing during the construction stage and subsequently form part of the Permanent Works, the Serviceability Limit State(SLS) checks shall be carried out both for "Construction" and "Service/Operation" stages.

#### **4.5 Deflection Criteria**

The deflection limitations imposed in IS 456 and IS 800 shall be followed for Concrete and Structural Steel elements respectively.

##### **4.5.1 Vertical Deflection Limits**

The deflection of a structure or part thereof shall not adversely affect the appearance or efficiency of the structure or finishes or partitions. The deflection shall be limited to the following.

##### **a) Retaining wall/ Diaphragm walls**

The maximum allowed calculated displacement for diaphragm wall in urban environment will be 35 mm corresponding to 25 mm vertical displacement at ground.

According to CIRIA C517 (Temporary Propping of Deep Excavation – Guidance on design, 1999), the comparative wall and ground movements of propped walls in deep uniform soils are as shown in the figure below (after Burland et al., 1979).

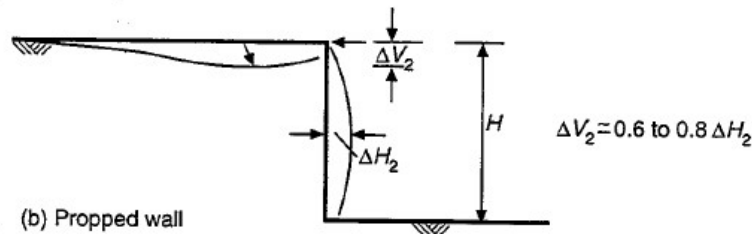

Hence, if  $\Delta V_2 = 25\text{mm}$  (permissible vertical displacement in adjacent buildings),

$$\Delta H_2 = 30 - 40 \text{ mm}$$

Anyway, a detailed analysis of the induced effects on buildings will have to be performed depending on their vulnerability. Accordingly, displacement for Retaining/Diaphragm wall shall be limited.

#### **b) Concrete structures**

The final deflection due to all loads including the effects of temperature, creep and shrinkage and measured from the as-cast level of the, supports of floors, roofs and all other horizontal members, should not exceed span/250.

The deflection including the effects of temperature, creep and shrinkage occurring after erection of partitions and the application of finishes should not normally exceed span/350 or 20 millimetres whichever is less.

#### **c) Steel structures**

Designs shall comply with the limits defined in IS 800.

### **4.6 Flotation**

1. Flotation shall be checked considering water table at ground level.
2. For protection against flotation the following shall apply.
  - a. A load factor of 0.9 shall be applied to the self-weight of the structure, including the first stage only of the track concrete.
  - b. A load factor of 0.9 shall be applied to the weight of backfill material over the structure.
  - c. A load factor of 0.5 shall be applied to the skin friction between the concrete surface and the soil.
  - d. The overall factor of safety against flotation shall not be less than 1.05 and 1.10 for any construction stage and after the completion of the Permanent Works respectively.

3. The Contractor shall check all proposed cut-and-cover structures (including ramps, cut and cover tunnels, box structures, stations etc) for the possibility of flotation due to differential water pressure and shall design each and every underground structure such that the factors of safety against flotation are achieved for all load cases. An additional check, in ULS condition considering all load factors to be 1.0, shall also be performed to ensure that the structures satisfy the strength criteria (capacity check) during the flotation condition. Seismic forces shall not be considered in this case.
4. The Contractor shall ensure that his method and sequence of construction is such that an adequate resistance to uplift is maintained at all times and shall put forward his proposal to this effect.
5. Suitable measures such as those listed below to counteract flotation forces for the Permanent Works shall be incorporated in the Contractor's design. The measure(s) chosen shall suit the particular conditions and the method of construction and may include:
  - a. Integration of D/wall with structure;
  - b. Toeing-in of the base slab into the surrounding ground;
  - c. increasing the dead weight of the structure by:
  - d. thickening of structural members;
  - e. providing an extra thickness of concrete beneath the base slab tied into the structural base slab;
  - f. extending the diaphragm walls;
  - g. providing counterweights in parts of the structure with high density material;
  - h. The provision of tension piles. For this purpose, the use of secant piled wall can be considered.
6. It will not normally be acceptable to modify the vertical alignment of the tunnels solely to counteract flotation forces. The use of ground anchors as a permanent measure to counteract flotation forces will not be permitted.
7. Where the base slab is toed-in to the surrounding ground a partial safety factor of 2.0 shall be applied to the shear resistance of the ground above the toe and the adhesion factor shall not apply. The value of the weight of ground above the toe shall be calculated as for the backfill material.
8. The value of the weight of any additional thickness of concrete shall take account of the increased volume of water displaced.

9. The Contractor shall ensure that his method and sequence of construction is such that an adequate resistance to uplift is maintained at all times and shall put forward his proposal to this effect.

10.  $K_0$  shall be considered as considered in wall design.

## **4.7 Civil Design Works**

### **4.7.1 Excavation Base Stability**

The Contractor's design shall include adequate precautions against base heave, piping and failure of his excavations during construction. The stability of the excavation bases shall be checked in accordance with an acceptable method of analysis which shall allow for all reasonable loads within and outside of the excavation.

The Contractor shall show in his calculations the contribution made to the base stability of the excavation by his proposed method of construction and shall state the factor(s) of safety used in the design. The factor(s) of safety shall relate to the method of construction and to the particular location of the Works and shall be subject to the notice of the Employer's Representative.

### **4.7.2 Excavation Toe Stability**

Design checks shall be performed to ensure adequate toe stability of retaining structure during construction. The toe stability shall be checked in accordance with an acceptable method of analysis, which shall allow for all reasonable loads within and outside of the excavation.

The conventional approach based on active and passive pressures shall be preferred with a minimum factor of safety shall be 1.3 under SLS condition considering partial safety factor of 1.0 on soil parameters.

### **4.7.3 Waterproofing**

For Water proofing, reference shall be made to Outline Construction Specification, Delhi Metro Phase-IV Civil Works.

### **4.7.4 Water Control in Excavations**

1. During construction in water-bearing ground, seepage water shall be controlled by suitable means and the design shall provide for the same. The Contractor shall obtain the Employer's Representative's prior notice to the process he intends to adopt to control groundwater inflow, and the treatment and disposal of any groundwater collected.
2. Soldier pile/contiguous piles shall not be permitted in case design ground water table is higher than excavation level.

3. Retractable type or GFRP Rock anchor shall be used in case of anchor is used for temporary retaining system.
4. The piezometric pressure outside of the excavations shall at all times remain within the normal expected groundwater variation and permissible safe limits. The Contractor shall be responsible for all local authority approvals required for his groundwater control methods.
5. Ground water table outside of excavation shall not be lowered more than 2.0 m from existing GWL. Suitable water recharge shall be done to maintain the water table.
6. Notwithstanding the limits on groundwater leakage rates, the design shall aim to ensure that no loss of ground or groundwater occurs through any part of the structure.

#### **4.7.5 Underpinning of Existing Building Structures (EBS)**

1. Where the construction of bored tunnels or other underground works necessitates the removal of existing support or foundations to existing buildings, structures, utilities, services, wells, pavements, road furniture and the like (collectively termed EBS) the Contractor shall carry out investigations on the extent of the existing works, their design and loading conditions.
2. The Contractor shall design and carry out such works as are necessary to maintain the integrity of the EBS at all times including its design life. No work shall commence prior to the notice of The Employer's Representative being given. Cost of design and provision of any support/strengthening of such structures will be deemed as included in the Contractor's Price.

#### **4.7.6 Seepage Barriers**

The Contractor shall provide seepage walls or barriers to all external underground walls that lie within public areas, staffrooms and plant-rooms, except for Pump, Environmental Control System and Tunnel Ventilation rooms, shafts and plenums. In the public area, the seepage barrier may be provided by either a finished wall with air gap behind or by architectural finishes mounted on framing attached to the external wall. In non-public areas a block or brickwork wall shall be provided. In all cases the Contractor shall design the seepage gap with a seepage drainage channel such that discolouration or water damage to the seepage walls cannot occur. Access panels to inspect and maintain the drains shall be included. All such finishes, panels and fixings and the like shall be non-corrodible and comply with the Contract design life requirements.

At platform level in the stations, the visual aspect of the platform walls must be aesthetically pleasing, and exposed diaphragm walls must be provided with a surface which will give a uniform finish without distinct changes in colour or alignment. All external trackside diaphragm walls must be either rendered or shotcrete or provided with another finish which has Notice of No Objection by the Engineer.

#### **4.7.7 Connection Details**

##### **4.7.7.1 Corners**

Particular attention shall be paid to corner joints of large structural members. External wall/slab junctions shall be provided with crack control steel and transverse ties. Radius of bend of main tension bars shall be increased to cater for the high bearing stresses within the bend.

##### **4.7.7.2 Construction Joints**

The design and detailing of construction joints shall be sufficient for the proposed works and the construction joints shall be minimised to reduce the risk of leakage.

##### **4.7.7.3 Slab to Wall Connections**

For top-down construction in particular, attention shall be paid to the practicalities of the design and detailing of the slab to wall connections and the means by which the integrity of the construction joints at these connections will be assured. Suitable cover values for slabs shall be adopted, as defined earlier, to arrive at the centre line of top and bottom bars in various slabs for design purposes.

##### **4.7.7.4 Connections between Bored, NATM and Cut-and-Cover Structures**

The design of connection joint shall consider the possibility of differential movement during both construction and in-service. The differential movement between the bored/NATM tunnel and cut-and-cover structure shall be sufficiently small so as not to cause overstressing of this joint which shall be designed to permit an appropriate degree of movement in all directions. Particular attention shall be paid to the waterproofing detail, to ensure that the water-tightness of this joint is not inferior to the standard joint between precast tunnel segments.

## **5. Temporary Works**

### **5.1 General Principles**

In general, Temporary Works shall be designed in accordance with the same design standards/principles as the Permanent Works. However, Earthquake forces shall also be considered for Temporary structures design. Existing water table shall be used for temporary structure design. Soil properties shall be same as permanent works.

The design of Temporary Works shall take account of all the applied external forces and imposed structural deformations and, where applicable, the effects of removal of load from the ground.

## **5.2 Design of Temporary Excavation Support**

Excavations for cut-and-cover structures in soft ground shall be supported by diaphragm walls, secant piles or similar which may be incorporated into the Permanent Works. Design of these elements shall include full step-by-step analyses of the progressive change in the loading and required temporary support conditions as the excavation proceeds and subsequently as these temporary elements are integrated into the Permanent Works.

Braced excavations shall be analysed by finite element or similar methods in which the changes in ground stresses are properly related to the deflections which occur in the structural elements, by the use of appropriate stiffness and other parameters. Relevant empirical evidence from similar excavations must be referred to in support of the conclusions of the analyses. Simplified analytical models and methods shall be employed to calibrate and support finite element analyses of the various permutations of structure geometry and loading.

Temporary works shall be designed as far as possible to be removed when no longer required and shall not be left in the ground. Temporary works which are viewed as being impossible to remove on completion of the Permanent Works shall be dismantled to a minimum depth of 2 metres below the finished ground surface and designed so that there will be no risk of ground settlement or other deleterious effects as a consequence of decay and/or collapse of these Temporary Works.

## **5.3 Ground Movements**

The Temporary and Permanent Works designs shall limit ground movement and distortions around the site and to avoid damage to adjacent EBS.

The Contractor shall carry out a risk assessment for all EBS within the influence of the Works in accordance with the Contract. The analyses for the Temporary Works shall be properly related to the conclusions of this risk assessment.

## **5.4 Construction Dewatering**

Temporary dewatering of construction excavations will be required to provide an undisturbed, stable and dry subgrade to permit construction and backfilling of the Permanent Works under dry conditions.

In general, the groundwater within the excavations shall be maintained at a level that permits achievement of the above and avoids heave, piping or base failure of the excavation.

Temporary dewatering methods and system operations, along with other required temporary works, shall not lower the groundwater outside the walls supporting the excavations, nor result in settlement, distortion or loss of ground at adjacent EBS.

The Contractor shall prepare and submit his design of his construction dewatering system to the Employer's Representative for his notice. The construction dewatering design shall include determination of subsurface conditions and geotechnical design parameters, analyses to establish feasible methods, and system definition in sufficient detail to demonstrate that the general objectives can be achieved without adverse effect on adjacent EBS. The selected system shall generally provide for continuous (24-hour-per-day) operation, adequate reserve equipment, and standby power.

## **5.5 Ground Improvement**

Ground-improvement may be required along certain alignment segments of the Metro Rail Corridors to control ground and EBS movement and distortion that may be induced by excavation and tunnelling and at tunnel break-in/break-out locations, in advance of bored tunnel excavation.

The Contractor shall prepare and submit his designs and method statements supported by analysis for all ground improvement to the Employer's Representative for his notice. These designs shall define performance objectives for the ground improvement.

Instrumentation, monitoring and reporting details for verifying achievement of ground improvement performance objectives in accordance with this Contract shall be included in the ground improvement design submission.

The information and assumptions on which the ground improvement is based shall be shown on the design drawings.

## **5.6 Instrumentation**

1. The Contractor shall instrument, monitor and report on ground and EBS movement and distortion, groundwater level, stress and displacement in the excavation and lateral support system, structural movement during construction to check his predictions.

2. Monitoring shall be carried out on a case-by-case day-to-day or more frequent basis depending upon the importance of the EBS and/or the risk of damage to that EBS. Special attention shall be paid to the historical buildings and wells located along the alignment.
3. Monitoring shall begin prior to commencement of the Works to enable instrument base-line values to be determined accurately and shall continue until all movements and distortions to the ground and EBS, and changes to the groundwater table that might be attributed to the Works, as shown by the monitoring, have effectively ceased for a period of three months.
4. The Contractor shall submit a complete comprehensive instrumentation, monitoring and reporting scheme with his Design and prior to any construction which is designed to achieve the following.
  - a) To establish typical background movement, distortion, groundwater fluctuation, and noise and vibration limits for the ground, groundwater and EBS prior to commencement of the Works.
  - b) Protection to all parties during and after the construction by providing early warning of any excessive and undue movement and distortion of the adjacent ground and EBS.
  - c) To provide movement and deformation information for design verification of the Temporary and Permanent Works.
  - d) To ensure that the maximum allowable tolerances associated with various structures/elements within the zone of influence of the Works are not exceeded.
  - e) To confirm that groundwater drawdown outside of the excavations does not exceed the expected fluctuation limits
5. Vibration recording devices shall be provided to monitor for vibrations which may cause damage to the proposed constructions and EBS. These devices shall be installed at intervals and locations to provide comprehensive coverage of the Works. Unless otherwise directed by the Fire/Life Safety Committee, these devices shall record ground accelerations generated by the Works to ensure that these accelerations do not exceed the values set by the relevant Authorities or those determined by the Contractor for the stability and safety of the Temporary and Permanent Works and adjacent EBS.

### **Limiting Construction-Induced Vibrations at adjacent EBS**

In the design, the effects of construction-related vibrations shall be considered. Unless otherwise accepted by the applicable government agencies and the Engineer

peak particle velocities at adjacent EBS shall not exceed the values in the Table below (as per AASHTO -1990 & DIN 4150 -3,1999):

## Peak Particle Velocities in mm/sec (Max. Allowable) at Adjacent EBS

Most structures in “good” condition	25
Most structures in “poor” condition	5
Most structures in “fair” condition	12
Water-supply structures	5
Heritage structures/bridge structures	5

Above limits are maximum permissible, however this may have to be restricted further if required to avoid damage to the adjacent EBS or causing discomfort to the occupants. Along the proposed alignment, other limitations may be imposed at adjacent EBS, such as hospitals, school buildings, telephone-exchange structures, special water-supply structures and Heritage structures etc.. In addition working hours for such equipments causing vibrations may have to be restricted, keeping the convenience and comfort of the occupants in mind.

### 5.7 Settlement and Building Protection

For settlement and Building Protection refer Chapter 12 of Bored Tunnel DBR.

## 6. List of Design Codes and Standards

A list of Codes and Standards is given for reference only.

(**Note:** the years of the codes mentioned below are notional, hence each time the designer shall adopt latest code with the latest correction slip)

### 6.1 Indian Railway Standards (IRS) Codes and Manuals

IRS	2008	Bridge Rules
IRS	1997	Concrete bridge Code (Reprint 2014)
IRS	1991	Bridge substructures and foundation code.
IRS	1997	Steel bridge Code
IRS	1998	Indian Railway Bridge Manual
IRS	1985	Manual on the Design and Construction of Well and Pile Foundations
IRS	2017	Earthquake resistant design of Railway Bridges

### 6.2 Indian Roads Congress Standards (IRC)

IRC 5:	2015	Standard Specifications and Code of Practice for Road Bridges. Section I – General Features of Design
IRC 6:	2017	Standard Specifications and Code of Practice for Road Bridges, Section II – Loads and Stresses

IRC 11:	1962	Recommended Practice for the Design of Layout of Cycle Tracks
IRC 19:	1977	Standard Specifications and Code of Practice for Water Bound Macadam
IRC 22:	2008	Standard Specifications and Code of Practice for Road Bridges, Section VI – Composite Construction
IRC 24:	2010	Standard Specifications and Code of Practice for Road Bridges, Section V – Steel Road Bridges
IRC 37:	1984	Guidelines for the Design of Flexible Pavement
IRC 45:	1972	Recommendations for Estimating the Resistance of Soil below the maximum Scour Level in the Design of Well Foundations of Bridges
IRC 48:	1972	Tentative Specifications for Bituminous Surface Dressing Using Pre-Coated Aggregates
IRC 78:	2014	Standard Specifications and Code of Practice for Road Bridges, Section VII Parts 1 and 2, Foundations and Substructure
IRC 87:	1984	Guidelines for the Design and Erection of False Work for Road Bridges
IRC 89:	1997	Guidelines for Design and Construction of River Training and Control Works for Road Bridges
IRC:	SP 11	1988 Handbook of Quality Control for Construction of Roads and Runways
IRC:112	2011	Code of Practice for Concrete Road Bridges

### **6.3 Bureau of Indian Standards Codes**

SP 7:	2005	National Building Code
IS 73:	1992	Paving Bitumen
IS 150:	1950	Ready mixed paint brushing, finishing stoving for enamel colour as required
IS 205:	1992	Non-ferrous metal Butt Hinges
IS 206:	1992	Tee and strap hinge
IS 207:	1964	Gate and shutter hooks and eyes
IS 208:	1987	Door handles
IS 210:	1993	Grey iron castings
IS 215:	1995	Road tar
IS 217:	1988	Cutback Bitumen
IS 269:	1989	33 grade Ordinary Portland Cement.
IS 278:	1978	Galvanised steel barbed wire for fencing
IS 280:	1978	Mild Steel wire for general engineering Purposes
IS 281:	1991	Mild Steel sliding door bolts for use with Padlocks

IS 362:	1991	Parliament hinges
IS 363:	1993	Hasps and staples
IS 383:	1970	Coarse and fine aggregates from natural Sources for concrete
IS 432:	1982	Mild steel and medium tensile steel bars and hard- drawn steel wire for concrete reinforcement Part 1 Mild steel and medium tensile steel bars Part 2 Hard-drawn steel wire
IS 453:	1993	Double-acting spring hinges
IS 455:	1989	Portland slag cement
IS 456:	2000	Code of practice for plain and reinforced concrete
IS 457:	1957	Code of practice for general construction of plain and reinforced concrete for dams and other massive structures
IS 458:	1988	Precast concrete pipes (with and without reinforcement)
IS 459:	1992	Corrugated and semi-corrugated asbestos cement sheets
IS 460:	1985	Test sieves
IS 516:	1959	Method of test for strength of concrete
IS 650:	1991	Standard sand for testing cement
IS 733:	1983	Wrought aluminium and aluminium alloy bars, rods and sections for general engineering purposes
IS 737:	1986	wrought aluminium and aluminium alloy sheet and strip for general engineering purposes
IS 771:	1979	Glazed fire-clay sanitary appliances Part 1 General requirements Part 2 Specific requirements of Kitchen and laboratory sinks Part 3/Sec. 1 Specific requirements of Urinals - Slab Urinals Part 3/Sec. 2 Specific requirements of Urinals - Stall Urinals
IS 774:	1984	Flushing cistern for water closets and urinals
IS 775:	1970	Cast iron brackets and supports for wash basins and sinks
IS 777:	1988	Glazed earthenware wall tiles
IS 778:	1984	Copper Alloy gate, globe and check valves for water works Purposes
IS 779:	1994	Water meters
IS 780:	1984	Sluice valves for water works purposes (50 to 300 mm size)
IS 781:	1984	Cast copper alloy screw down bib taps and stop valves for water service
IS 783:	1985	Code of practice for laying of concrete pipes
IS 800:	2007	Code of practice for general construction in steel
IS 814:	1991	Covered electrodes for manual metal arc welding of carbon and carbon manganese steel

IS 875:	1987	Code of practice for design loads (other than earthquake) for buildings and structures
IS 883:	1994	Code of practice for design of structural timber in building
IS 909:	1992	Under-ground fire hydrant, sluice valve type
IS 1003:		Timber panelled and glazed shutters Part 1 1991 Door shutters Part 2 1994 Window and ventilator shutters
IS 1030:	1989	Carbon steel castings for general engineering purposes
IS 1038:	1983	Steel doors, windows and ventilators
IS 1077:	1992	Common burnt, clay building bricks
IS 1080:	1986	Design and construction of shallow foundation in soil (other than raft ring and shell)
IS 1161:	1979	Steel tubes for structural purposes
IS 1195:	1978	Bitumen mastic for flooring
IS 1200	Part 1	Methodology of measurement of Building and Civil Engineering Works.
IS 1230:	1979	Cast iron rainwater pipes and fittings
IS 1237:	1980	Cement concrete flooring tiles
IS 1239:	1990	Mild steel tubes, tubular and other wrought steel fittings Part 1 Mild steel tubes Part 2 Mild steel tubular and other wrought steel pipe fittings
IS 1322:	1993	Bitumen felts for water proofing and damp-proofing
IS 1341:	1992	Steel butt hinges
IS 1343:	1980	Code of practice for Pre-Stressed Concrete
IS 1346:	1991	Code of practice Waterproofing of roofs with bitumen felts
IS 1458:	1965	Railway bronze ingots and casting
IS 1489:	1991	Portland Pozzolana Cement
IS 1536:	1989	Centrifugally cast (spun) iron pressure pipes for water, gas and sewage
IS 1537:	1976	Vertically cast-iron pressure pipes for water, gas and sewage
IS 1538:	1993	Cast iron fittings for pressure pipes for water, gas and sewage
IS 1566:	1982	Hard-drawn steel wire fabric for concrete reinforcement IS
IS 1592:	1989	Asbestos cement pressure pipes
IS 1703:	1989	Copper alloy float valves (horizontal plunger type) for water supply fittings
IS 1726:	1991	Cast iron manhole covers and frames
IS 1729:	1979	Sand cast iron spigot and socket soil waste and ventilating pipes, fitting and accessories

IS 1732:	1989	Dimensions for round and square steel bars for structural and general engineering purposes
IS 1785:	1983	Plain hard-drawn steel wire for prestressed concrete Part 1 Cold-drawn stress – relieved wire Part 2 As drawn wire
IS 1786:	1985	High strength deformed steel bars and wires for concrete reinforcement
IS 1791:	1985	Batch type concrete mixers
IS 1795:	1982	Specifications for pillar taps for water supply purposes
IS 1834:	1984	Hot applied sealing compounds for joint in concrete
IS 1838:	1983	Pre-formed fillers for expansion joint in concrete pavements and structures (non extruding and resilient type) Part 1 Bitumen impregnated fibre
IS 1888:	1982	Method of load tests on soils
IS 1892:	1979	Code of practice for sub surface investigations for foundations
IS 1893	2016	Criteria for earthquake resistant design of structures, Part 1 General Provisions and Buildings
IS 1904	1986	Design and construction of foundations in soils General Requirements
IS 1948:	1961	Aluminium doors, windows and ventilators
IS 1949:	1961	Aluminium windows for industrial buildings
IS 1977:	1976	Low Tensile Structural steel
IS 2004:	1991	Carbon steel forgings for general engineering purposes
IS 2062:	2006	Steel for general structural purposes
IS 2074:	1992	Ready mixed paint, air-drying, red oxide-zinc chrome, Priming
IS 2090:	1983	High tensile steel bars used in prestressed concrete
IS 2114:	1984	Code of practice for laying in-situ terrazzo floor finish
IS 2116:	1980	Sand for masonry mortars
IS 2119:	1980	Code of practice for construction of brick-cum-concrete composite
IS 2202:	1991	Wooden flush door shutters
IS 2326:	1987	Automatic flushing cisterns for urinals
IS 2386:	1963	Methods of test for aggregates for concrete Part 1 Particle size and shape Part 2 Estimation of deleterious materials and organic impurities Part 3 Specific gravity, density, voids, absorption and bulking Part 4 Mechanical properties Part 5 Soundness Part 6 Measuring mortar making properties of fine aggregates Part 7 Alkali – aggregate reactivity

		Part 8 Petrographic examination
IS 2430:	1986	Methods of sampling of aggregate for concrete
IS 2548:	1996	Plastic seats and covers for water closets
IS 2681:	1993	Non-ferrous metal sliding door bolts (aldrops) for use with padlocks
IS 2690:	1993	Burnt - clay for flat terracing Tiles
IS 2692:	1989	Ferrules for water services
IS 2720	1972-2002	Methods of Tests for Soils (all Parts)
IS 2751:	1979	Recommended practice for welding of mild steel plain and deformed bars used for reinforced construction
IS 2906:	1984	Specification for sluice valves for water works purposes (350 to1200 mm size)
IS 2911:	2010	Code of practice for design and construction of pile foundations Part 1 Concrete piles Section 1 Driven cast –in-situ concrete piles Section 2 Bored cast-in-situ concrete piles Section 3 Driven precast concrete piles Section 4 Bored precast concrete piles Part 3 Under-reamed piles Part 4 Load test on piles
IS 2950:	1981	Code of practice for design and construction of raft foundations.
IS 3067	1988:	Code of Practice for General Design Details and Preparatory Work for Damp-Proofing and Water-Proofing of Buildings
IS 3370:	2009	Code of practice for concrete structures for the storage of liquids
IS 3564:	1995	Hydraulically regulated door closers
IS 3812:	1981	Fly ash for use as pozzolan and admixture
IS 3847:	1992	Mortice night latches
IS 3955:	1967	Code of practice for design and construction of well foundations
IS 3989:	1984	Centrifugally cast (spun) iron spigot and socket soil, waste and ventilating pipes, fittings and accessories
IS 4082:	1996	Recommendations on stacking and storage of construction materials and components at site
IS 4138:	1977	Safety code for working in compressed air
IS 4326:	1993	Earthquake resistant design and construction of buildings – code of practice
IS 4656:	1968	Form vibrators for concrete
IS 4736:	1986	Hot-dip zinc coatings on mild steel tubes
IS 4826:	1979	Hot-dipped galvanised coatings on round steel wires
IS 4925:	1968	Concrete batching and mixing plant

IS 4926:	1976	Ready mixed concrete
IS 4968:	1976	Method for sub surface sounding for soils
IS 5525:	1969	Recommendations for detailing of reinforcement in reinforced concrete works
IS 5529:	1985	Code of practice for in-situ permeability tests
IS 5640:	1970	Method of test for determining aggregate impact value of soft coarse aggregate
IS 5816:	1970	Method of test for splitting tensile strength of concrete cylinders
IS 5889:	1994	Vibratory plate compactor
IS 5892:	1970	Concrete transit mixers and agitators
IS 6003:	1983	Specification for indented wire for prestressed concrete
IS 6006:	1983	Specification for uncoated stress relieved strands for prestressed concrete
IS 6051:	1970	Code for designation of aluminium and its alloys
IS 6248:	1979	Specification for metal rolling shutters and rolling grills
IS 6403:	1981	Code of practice for determination of bearing capacity of shallow foundations
IS 6603:	1972	Stainless steel bars and flats
IS 6760:	1972	Slotted countersunk head wood screws
IS 6911:	1992	Stainless steel plate, sheet and strip
IS 7181:	1986	Horizontally cast-iron double flanged pipes for water, gas and sewage
IS 7196:	1974	Hold fast
IS 7205:	1974	Safety code for erection of structural steel work
IS 7231:	1984	Specifications for plastic flushing cisterns for water closets and urinals
IS 7273:	1974	Method of testing fusion-welded joints in aluminium and aluminium alloys
IS 7293:	1974	Safety code for working with construction machinery
IS 7320:	1974	Concrete slump test apparatus
IS 7534:	1985	Sliding locking bolts for use with padlocks
IS 7861:	1975	Code of practice for extreme weather concreting Part 1 For Hot Weather concreting Part 2 For Cold Weather concreting
IS 7969:	1975	Safety code for handling and storage of building Materials
IS 8009:	1976	Calculation of settlement of foundations
IS 8041:	1990	Rapid – hardening Portland cement
IS 8112:	1989	43 grade ordinary Portland cement

IS 8142:	1994	Method of test for determining setting time of concrete by penetration resistance
IS 8500:	1991	Structural steel-micro alloyed (medium and high strength qualities)
IS 9013:	1978	Method of making, curing and determining compressive strength of accelerated cured concrete test specimens
IS 9103:	1979	Admixtures for concrete
IS 9284:	1979	Method of test for abrasion resistance of concrete
IS 9417:	1989	Recommendations for welding cold worked bars for reinforced concrete construction
IS 9595:	1996	Recommendations for metal arc welding of carbon and carbon manganese steels
IS 9762:	1994	Polyethylene floats (spherical) for float valves
IS 10262:	2009	Recommended guidelines for concrete mix design
IS 10379:	1982	Code of practice for field control of moisture and compaction of soils for embankment and subgrade
IS 10500:	1991	Drinking water specification
IS 12269:	1987	53 grade ordinary Portland cement
IS 12894:	1990	Fly ash lime bricks
IS 13630:	1994	Ceramic tiles – methods of tests
IS 13920:	2016	Ductile detailing of reinforced concrete structures subjected to seismic forces
IS 15388:	2003	Specifications for Silica Fume
SP 36	(Part 1):	Compendium of Indian Standards on Soil Engineering (Laboratory Testing)
SP 36	(Part 2):	Compendium of Indian Standards on Soil Engineering (Field Testing) Indian Standard Hand Book on Steel Sections Part-I CRRRI and IOC, New Delhi Bituminous Road Construction Hand Book

#### 6.4 British Standards

BS 812		Testing Aggregates - Parts 117 to 119.
BS 1377		Methods of Test for Civil Engineering Purposes - Parts 1 thru 9.
BS 4395	Part 2	High strength friction grip bolts and associated nuts and washers for Structural Engineering Higher Grade
BS 4447		The performance of pre-stressing anchorages for post-tensioned construction
BS 4449		Specification for Carbon Steel Bars for the Reinforcement of Concrete
BS 4486		Hot rolled and hot rolled & processed high tensile alloy steel bars for

		pre-tensioning of concrete
BS 4550		Methods of testing cement
BS 4592		Industrial Type Metal Flooring, walkways and stair treads
BS 4604	Part 2	The use of high strength friction grip bolts in structural steel work. Higher grade (parallel shank)
BS 4870		Approval testing of welding procedures
BS 4871		Approval testing of welders working to approved welding Procedures
BS 4872		Approval testing of welders when welding procedure approval is not required
BS 5075		Concrete admixtures
BS 5135		Process of arc welding of carbon and carbon manganese Steels
BS 5212	Part 2	Cold poured joint sealants for concrete pavements
BS 5328		Methods for specifying concrete, including ready mixed Concrete
BS 5400		Steel, concrete and composite bridges
BS 5400	Part 4	Code of practice for design of concrete bridges
BS 5400	Part 6	Specification for materials and workmanship, steel
BS 5606		Accuracy in building
BS 5896		High tensile steel wire and stand for the pre-stressing of concrete.
BS 5930:		Code of Practice for Site Investigations.
BS 5950	Part 2	Specification for materials, fabrication and erection: hot rolled sections
BS 6031		Code of Practice for Earthworks.
BS 6105		Corrosion-resistant stainless-steel fasteners
BS 6164		Safety in tunnelling in the construction industry.
BS 6349		Code of Practice for Dredging and Land Reclamation.
BS 6443		Penetrant flaw detection
BS 6681		Specification for malleable cast iron
BS 7079		Preparation of Steel substrates before application of paints and related products
BS 7385	Part 2	Evaluation and measurement for Vibrations in Buildings – E to Damage levels from Ground-Borne Vibrations
BS 7542		method of test for curing compound for concrete
BS 8000	Part 4	Code of Practice for Waterproofing
BS 8000	Part 5	Code of Practice for Below Ground Drainage
BS 8002		Code of Practice for Earth Retaining Structures
BS 8004		Code of Practice for Foundations
BS 8007		Design of Concrete Structures for Retaining Aqueous Liquids

BS 8081		Code of Practice for Ground Anchorages
BS 8110		Structural use of concrete
BS 8301	Section 5	Code of practice for building drainage
BS 8550		Concrete – Specification of Materials
BS EN	1997	Eurocode 7: Geotechnical design
BS EN	1998	Eurocode 8: Design of structure for earthquake resistance
CIRIA	Report 44	Medical Code of Practice for working in compressed air
CIRIA	Report 80	A review of instruments for gas and dust monitoring Underground
CIRIA	Report 81	Tunnel water proofing
CIRIA	Report	Groundwater Control – Design and Practice
	C515	
CIRIA	Report	Embedded Retaining Walls – Guidance for Economic Design
	C580	
CIRIA	Report	Early Age Thermal Crack Control in Concrete
	C660	

## 6.5 ASTM Standards

ASTM	C-1202	Test methods for Electrical indication of concrete's ability to resist chloride ion penetration.
ASTM	C-1240	Micro Silica/Silica fume in concrete
ASTM	D-297	Methods for Rubber Products-Chemical Analysis
ASTM	D-395	Compression set of vulcanized rubber
ASTM	D-412	Tension testing of vulcanized rubber
ASTM	D-429	Adhesion of vulcanized rubber to metal
ASTM	D-573	Accelerated aging of vulcanized rubber by the oven method
ASTM	D-624	Tear resistance of vulcanized rubber
ASTM	D-797	Young's modulus in flexure of elastomer at normal and subnormal temperature
ASTM	D-1075	Effect of water on cohesion of compacted bituminous mixtures
ASTM	D-1143	Test method for piles under static axial comp. test
ASTM	D-1149	Accelerated ozone cracking of vulcanized rubber
ASTM	D-1556	In-situ density by sand replacement
ASTM	D-1559	Test for resistance to plastic flow of bituminous mixtures using Marshall apparatus
ASTM	D-2172	Extraction, quantitative, of bitumen from bituminous paving mixtures
ASTM	D-2240	Indentation hardness of rubber and plastic by means of a Durometer
ASTM	D-3689	Testing method of testing individual piles under static axial tensile load

ASTM	D-4945	Test method for high strain dynamic testing of piles
ASTM	E-11	Specification for wire cloth sieve for testing purpose
ASTM:	Section 4:	Construction, Vol. 04.08: Soil and Rock I, and Volume 04.09: Soil and Rock II,

## 6.6 AASHTO Standards

AASHTO	M6-81	Fine aggregate for Portland cement concrete
AASHTO	M31-82	Deformed and plain billet-steel bars for concrete reinforcement
AASHTO	M42-81	Rail-steel deformed and plain bars for concrete reinforcement
AASHTO	M54-81	Fabricated steel bar or rod mats for concrete reinforcement
AASHTO	M 81-75	Cut-back asphalt (rapid-curing type)
AASHTO	M 82-75	Cut-back asphalt (medium-curing type)
AASHTO	M85-80	Portland cement
AASHTO	M 140-80	Emulsified asphalt
AASHTO	M 147-67	Materials for aggregate and soil–aggregate sub-base, base and surface courses
AASHTO	M148-82	Liquid membrane-forming compounds for curing concrete
AASHTO	M154-79	Air-Entraining admixtures for concrete
AASHTO	M173-60	Concrete joint-sealer, hot-poured elastic type
AASHTO	M194-82	Chemical admixtures for concrete
AASHTO	M213-81	Preformed expansion joint fillers for concrete paving and structural construction
AASHTO	M 282-80	Joints sealants, hot poured, elastomeric-type, for port-land cement concrete pavements
AASHTO	M 294-70	Fine aggregate for bituminous paving mixtures
AASHTO	T22-82	Compressive strength of cylindrical concrete specimens
AASHTO	T23-80	Making and curing concrete compressive and flexural strength test specimens in the field
AASHTO	T26-79	Quality of water to be used in concrete
AASHTO	T96-77	Resistance to abrasion of small size coarse aggregate by use of the Los Angeles machine
AASHTO	T99-81	The moisture-density relations of soils using a 5.5-lb (2.5kg) rammer and a 12-in (305mm) Drop
ASHTO	104-77	Soundness of aggregate by use of sodium sulphate or magnesium sulphate
AASHTO	T176-73	Plastic fines in graded aggregates and soil by use of the sand equivalent test

AASHTO	T180-74	The moisture density relations of soils using a 10-lb (4.54kg) rammer and an 18-in (457mm) Drop
AASHTO	T182-82	Coating and stripping of bitumen-aggregate mixtures
AASHTO	T191-61	Density of soil In-place by the sand-cone method

## 6.7 Other Publications

American Petroleum Industry (API) Standard 1104		
UIC/772-R		The International Union of Railway Publication
SS 460 48 66 1992		Swedish Standard Vibration and Shock Guidance Levels for Blast-induced vibration
NS8141	1993	Vibration and Shock in Structure, Guidance Limits for Blasting-Induced Vibrations
National Fire Protection Association, NFPA 130-2010:		Standard for Fixed Guideway Transit and Passenger Rail Systems
International Society for Rock Mechanics (ISRM), Suggested Test Methods, (various dates)		
British Tunnelling Society		Specification for Tunnelling
Austrian Society for Rock Mechanics:		Geotechnical Ground Structures Design
International Tunnel Association		Guidelines for the Design and Analysis of Underground Structure
ITA/AITES Accredited Material		Seismic Design and Analysis of Underground Structures
Muir Wood, A.M. (1975)		The Circular Tunnel in Elastic Ground
D.J. Curtis et al (1976)		Discussion Paper - Circular Tunnel in Elastic Ground
CG Lai et al (2000)		Probabilistic Seismic Hazard Assessment and Stochastic Sire Response Analysis at the Archaeological Site of Kancheepuram in Southern India. IUSS Press

## 7. ANNEXURE A (LOAD COMBINATION)

L/C No.	Descriptions of Load Case	ULS STATIC																	
		Submerged Water @ GL							Saturated Soil										
		1001	1002	1003	1004	1005	1006	1007	1008	1009	1010	1011	1012	1013	1014	1015			
<b>1</b>	Self Weight	(MAX H - MAX V) without LL	1.5	1.5	1	1.5	1.5	1.5	1.5	1.5	1.5	1.5	1.5	1	1.5	1.5	1.5	1.5	(MAX H - MAX V) without LL
<b>2</b>	SIDL	(MAX H - MAX V) without LL	1.5	1.5	1	1.5	1.5	1.5	1.5	1.5	1.5	1.5	1.5	1	1.5	1.5	1.5	1.5	(MAX H - MAX V) without LL
<b>3</b>	Soil Back Fill	(MAX H - MAX V) without LL	1.5	1.5	1	1.5	1.5	1.5	1.5	1.5	1.5	1.5	1.5	1	1.5	1.5	1.5	1.5	(MAX H - MAX V) without LL
<b>4</b>	Live Load on concourse & platform	(MAX H - MAX V) without LL	1.5	0	0	1.5	0	1.5	0	1.5	0	1.5	0	0	1.5	0	1.5	0	(MAX H - MAX V) without LL
<b>5</b>	Train Live Load	(MAX H - MAX V) without LL	1.5	0	0	1.5	0	1.5	0	1.5	0	1.5	0	0	1.5	0	1.5	0	(MAX H - MAX V) without LL
<b>6</b>	Lateral Earth Pressure Sub (GWL @ HRL) K0	(MAX H - MAX V) without LL	1.5	1.5	1.5	0	0	0	0	0	0	0	0	0	0	0	0	0	(MAX H - MAX V) without LL
<b>7</b>	Lateral Earth Pressure Sub (GWL @ HRL) Ka	(MAX H - MAX V) without LL	0	0	1	1	0	0	0	0	0	0	0	0	0	0	0	0	(MAX H - MAX V) without LL
<b>8</b>	Lateral Earth Pressure Sub (GWL @ GL) K0	(MAX H - MAX V) without LL	0	0	0	0	1.5	1.5	1.5	0	0	0	0	0	0	0	0	0	(MAX H - MAX V) without LL
<b>9</b>	Lateral Earth Pressure Sub (GWL @ GL) Ka	(MAX H - MAX V) without LL	0	0	0	0	0	0	0	0	1	1	0	0	0	0	0	0	(MAX H - MAX V) without LL
<b>10</b>	Lateral Earth Pressure Sat_ K0	(MAX H - MAX V) without LL	0	0	0	0	0	0	0	0	0	0	0	0	1.5	1.5	1.5	0	(MAX H - MAX V) without LL
<b>11</b>	Lateral Earth Pressure Sat_ Ka	(MAX H - MAX V) without LL	0	0	0	0	0	0	0	0	0	0	0	0	0	0	0	0	(MAX H - MAX V) without LL
<b>12</b>	Vertical Surcharge Load	(MAX H - MAX V) without LL	1.5	1.5	0	1.5	1.5	1.5	1.5	0	1.5	1.5	1.5	0	1.5	1.5	1.5	0	(MAX H - MAX V) without LL
<b>13</b>	Surcharge load (Towards Right)	(MAX H - MAX V) without LL	0	0	0	0	0	0	0	0	0	0	0	0	0	0	0	0	(MAX H - MAX V) without LL
<b>14</b>	Surcharge load (Towards Left)	(MAX H - MAX V) without LL	0	0	0	0	0	0	0	0	0	0	0	0	0	0	0	0	(MAX H - MAX V) without LL
<b>15</b>	Surcharge load (Both Sides)	(MAX H - MAX V) without LL	1.5	1.5	1.5	0	0	1.5	1.5	0	0	1.5	1.5	0	1.5	1.5	1.5	0	(MAX H - MAX V) without LL
<b>16</b>	Water Pressure (HRL) (Lateral)	(MAX H - MAX V) without LL	1.5	1.5	1.5	1	1	0	0	0	0	0	0	0	0	0	0	0	(MAX H - MAX V) without LL
<b>17</b>	Water Pressure (HRL) (Vertical) Uplift case	(MAX H - MAX V) without LL	1.5	1.5	1	1.5	1.5	0	0	0	0	0	0	0	0	0	0	0	(MAX H - MAX V) without LL
<b>18</b>	Water Pressure at design water table level	(MAX H - MAX V) without LL	0	0	0	0	0	1.3	1.3	1.3	1	1	0	0	0	0	0	0	(MAX H - MAX V) without LL
<b>19</b>	Water Pressure at design water table level (uplift)	(MAX H - MAX V) without LL	0	0	0	0	0	1.3	1.3	1.3	1	1.3	0	0	0	0	0	0	(MAX H - MAX V) without LL
<b>20</b>	0.18 g Racking Point Force (Towards Right)	(MAX H - MAX V) without LL	0	0	0	0	0	0	0	0	0	0	0	0	0	0	0	0	(MAX H - MAX V) without LL
<b>21</b>	0.18 g Racking Point Force (Towards Left)	(MAX H - MAX V) without LL	0	0	0	0	0	0	0	0	0	0	0	0	0	0	0	0	(MAX H - MAX V) without LL
<b>22</b>	0.18 g Racking Distribution Force (Towards Right)	(MAX H - MAX V) without LL	0	0	0	0	0	0	0	0	0	0	0	0	0	0	0	0	(MAX H - MAX V) without LL
<b>23</b>	0.18 g Racking Distribution Force (Towards Left)	(MAX H - MAX V) without LL	0	0	0	0	0	0	0	0	0	0	0	0	0	0	0	0	(MAX H - MAX V) without LL
<b>24</b>	0.36 g Racking Point Force (Towards Right)	(MAX H - MAX V) without LL	0	0	0	0	0	0	0	0	0	0	0	0	0	0	0	0	(MAX H - MAX V) without LL
<b>25</b>	0.36 g Racking Point Force (Towards Left)	(MAX H - MAX V) without LL	0	0	0	0	0	0	0	0	0	0	0	0	0	0	0	0	(MAX H - MAX V) without LL
<b>26</b>	0.36 g Racking Distribution Force (Towards Right)	(MAX H - MAX V) without LL	0	0	0	0	0	0	0	0	0	0	0	0	0	0	0	0	(MAX H - MAX V) without LL
<b>27</b>	0.36 g Racking Distribution Force (Towards Left)	(MAX H - MAX V) without LL	0	0	0	0	0	0	0	0	0	0	0	0	0	0	0	0	(MAX H - MAX V) without LL

L/C No.		ULS SEISMIC (RACKING) CORRESPONDING TO 0.18g													
		2001	2002	2003	2004	2005	2006	2007	2008	2009	2010	2011	2012	2013	2014
		Submerged Water @ GL													
Descriptions of Load Case		1.5 DL + 1.5 EQ						1.2 DL + 1.2 LL + 1.5 EQ							
		(MAX H - MAX V)	(MAX H - MIN V)	(MAX H - MIN V)	(MAX H - MIN V)	(MAX H - MIN V)	(MAX H - MIN V)	(MAX H - MAX V)	(MAX H - MIN V)	(MAX H - MIN V)	(MAX H - MAX V)	(MAX H - MAX V)	(MAX H - MAX V)	(MAX H - MAX V)	
1	Self Weight	1.5	1.5	1.5	1.5	1.5	1.5	1.5	1.5	1.5	1.2	1.2	1.2	1	1
2	SIDL	1.5	1.5	1.5	1.5	1.5	1.5	1.5	1.5	1.5	1.2	1.2	1.2	1	1
3	Soil Back Fill	1.5	1.5	1.5	1.5	1.5	1.5	1.5	1.5	1.5	1.2	1.2	1.2	1	1
4	Live Load on concourse & platform	0	0	0	0	0	0	0	0	0	0.6	0.6	0.6	0.5	0.5
5	Train Live Load	0	0	0	0	0	0	0	0	0	1.2	1.2	1.2	1	1
6	Lateral Earth Pressure Sub (GWL @ HRL) K0	1.5	1.5	1.5	1.5	1.5	1.5	1.5	1.5	1.5	0	0	0	0	0
7	Lateral Earth Pressure Sub (GWL @ HRL) Ka	0	0	0	0	0	0	0	0	0	0	0	0	0	0
8	Lateral Earth Pressure Sub (GWL @ GL) K0	0	0	0	0	1.5	1.5	1.5	1.5	1.5	1.2	1.2	1.2	1	1
9	Lateral Earth Pressure Sub (GWL @ GL) Ka	0	0	0	0	0	0	0	0	0	0	0	0	0	0
10	Lateral Earth Pressure Sat. K0	0	0	0	0	0	0	0	0	0	0	0	0	0	0
11	Lateral Earth Pressure Sat. Ka	0	0	0	0	0	0	0	0	0	0	0	0	0	0
12	Vertical Surcharge Load	1.5	1.5	1.5	1.5	1.5	1.5	1.5	1.5	1.5	1.2	1.2	1.2	1	1
13	Surcharge load (Towards Right)	1.5	0	1.5	0	1.5	0	1.5	0	1.5	1.2	1.2	1.2	1	1
14	Surcharge load (Towards Left)	0	1.5	0	1.5	0	1.5	0	1.5	0	1.2	1.2	1.2	1	1
15	Surcharge load (Both Sides)	0	0	0	0	0	0	0	0	0	0	0	0	0	0
16	Water Pressure (HRL) (Lateral)	1.5	1.5	1.5	1.5	1.5	1.5	1.5	1.5	1.5	0	0	0	0	0
17	Water Pressure (HRL) (Vertical) Uplift case	1.5	1.5	1.5	1.5	1.5	1.5	1.5	1.5	1.5	0	0	0	0	0
18	Water Pressure at design water table level	0	0	0	0	1.3	1.3	1.3	1.3	1.3	1.2	1.2	1.2	1	1
19	Water Pressure at design water table level (uplift)	0	0	0	0	1.3	1.3	1.3	1.3	1.3	1.2	1.2	1.2	1	1
20	0.18 g Racking Point Force (Towards Right)	1.5	0	0	0	0	0	1.5	0	0	1.2	1.2	1.2	1	1
21	0.18 g Racking Point Force (Towards Left)	0	1.5	0	0	0	0	0	1.5	0	0	0	0	0	0
22	0.18 g Racking Distribution Force (Towards Right)	0	0	1.5	0	0	0	0	0	0	1.2	1.2	1.2	1	1
23	0.18 g Racking Distribution Force (Towards Left)	0	0	0	1.5	0	0	0	0	0	0	0	1.2	1	1
24	0.36 g Racking Point Force (Towards Right)	0	0	0	0	0	0	0	0	0	0	0	0	1	0
25	0.36 g Racking Point Force (Towards Left)	0	0	0	0	0	0	0	0	0	0	0	0	0	1
26	0.36 g Racking Distribution Force (Towards Right)	0	0	0	0	0	0	0	0	0	0	0	0	0	0
27	0.36 g Racking Distribution Force (Towards Left)	0	0	0	0	0	0	0	0	0	0	0	0	0	0

L/C No.	Descriptions of Load Case	ULS SEISMIC (RACKING) corresponding to 0.36 g														
		2015	2016	2017	2018	2019	2020	2021	2022	2023	2024	2025	2026	2027	2028	
		Submerged Water @ GL														
	( MAX H - MAX V)	( MAX H - MIN V)	( MAX H - MIN V)	( MAX H - MIN V)	( MAX H - MIN V)	( MAX H - MIN V)	( MAX H - MIN V)	( MAX H - MIN V)	( MAX H - MIN V)	( MAX H - MIN V)	( MAX H - MIN V)	( MAX H - MIN V)	( MAX H - MIN V)	( MAX H - MIN V)	( MIN H - MAX V)	
1	Self Weight	1	1	1	1	1	1	1	1	1	1	1	1	1	1.2	1.2
2	SIDL	1	1	1	1	1	1	1	1	1	1	1	1	1	1.2	1.2
3	Soil Back Fill	1	1	1	1	1	1	1	1	1	1	1	1	1	1.2	1.2
4	Live Load on concourse & platform	0.5	0.5	0	0	0	0	0	0	0	0	0	0	0	0.6	0.6
5	Train Live Load	1	1	0	0	0	0	0	0	0	0	0	0	0	1.2	1.2
6	Lateral Earth Pressure Sub (GWL @ HRL) K0	0	0	0	0	0	0	0	0	0	0	0	0	0	0	0
7	Lateral Earth Pressure Sub (GWL @ HRL) Ka	0	0	0	0	0	0	0	0	0	0	0	0	0	0	0
8	Lateral Earth Pressure Sub (GWL @ GL) K0	1	1	1.2	1.2	1.2	1.2	1.2	1	1	1	1	1	1	0	0
9	Lateral Earth Pressure Sub (GWL @ GL) Ka	0	0	0	0	0	0	0	0	0	0	0	0	0	1	1
10	Lateral Earth Pressure Sat_K0	0	0	0	0	0	0	0	0	0	0	0	0	0	0	0
11	Lateral Earth Pressure Sat_Ka	0	0	0	0	0	0	0	0	0	0	0	0	0	0	0
12	Vertical Surcharge Load	1	1	0	0	0	0	0	0	0	0	0	0	0	1.2	1.2
13	Surcharge load (Towards Right)	1	0	1.2	0	1.2	0	1.2	0	1	0	1	0	1	0	0
14	Surcharge load (Towards Left)	0	1	0	1.2	0	1.2	0	1.2	0	1	0	1	0	0	0
15	Surcharge load (Both Sides)	0	0	0	0	0	0	0	0	0	0	0	0	0	0	0
16	Water Pressure (HRL) (Lateral)	0	0	0	0	0	0	0	0	0	0	0	0	0	0	0
17	Water Pressure (HRL) (Vertical) Uplift case	0	0	0	0	0	0	0	0	0	0	0	0	0	0	0
18	Water Pressure at design water table level	1	1	1.2	1.2	1.2	1.2	1.2	1	1	1	1	1	1	1	1
19	Water Pressure at design water table level (uplift)	1	1	1	1	1	1	1	1	1	1	1	1	1	1.2	1.2
20	0.18 g Racking Point Force (Towards Right)	0	0	1.2	0	0	0	0	0	0	0	0	0	0	1	0
21	0.18 g Racking Point Force (Towards Left)	0	0	0	1.2	0	0	0	0	0	0	0	0	0	0	0
22	0.18 g Racking Distribution Force (Towards Right)	0	0	0	0	0	0	0	0	0	0	0	0	0	1	0
23	0.18 g Racking Distribution Force (Towards Left)	0	0	0	0	0	0	0	0	0	0	0	0	0	0	1
24	0.36 g Racking Point Force (Towards Right)	0	0	0	0	0	0	0	0	0	0	0	0	0	0	0
25	0.36 g Racking Point Force (Towards Left)	0	0	0	0	0	0	0	0	0	0	0	0	0	0	0
26	0.36 g Racking Distribution Force (Towards Right)	1	1	0	0	0	0	0	0	0	0	0	0	0	0	0
27	0.36 g Racking Distribution Force (Towards Left)	0	1	0	0	0	0	0	0	0	0	0	0	0	0	0

L/C No.	Descriptions of Load Case	ULS SEISMIC (RACKING) CORRESPONDING TO 0.18g									
		2101	2102	2103	2104	2105	2106	2107	2108	2109	2110
		Saturated soil									
					(MAX H - MAX V)	(MAX H - MAX V)	(MAX H - MAX V)	(MAX H - MAX V)	(MAX H - MIN V)	(MAX H - MIN V)	
1	Self Weight	1.5	1.5	1.5	1.5	1.2	1.2	1.2	1.2	1	1
2	SIDL	1.5	1.5	1.5	1.5	1.2	1.2	1.2	1.2	1	1
3	Soil Back Fill	1.5	1.5	1.5	1.5	1.2	1.2	1.2	1.2	1	1
4	Live Load on concourse & platform	0	0	0	0	0.6	0.6	0.6	0.6	0	0
5	Train Live Load	0	0	0	0	1.2	1.2	1.2	1.2	0	0
6	Lateral Earth Pressure Sub (GWL @ HRL) K0	0	0	0	0	0	0	0	0	0	0
7	Lateral Earth Pressure Sub (GWL @ HRL) Ka	0	0	0	0	0	0	0	0	0	0
8	Lateral Earth Pressure Sub (GWL @ GL) K0	0	0	0	0	0	0	0	0	0	0
9	Lateral Earth Pressure Sub (GWL @ GL) Ka	0	0	0	0	0	0	0	0	0	0
10	Lateral Earth Pressure Sat_ K0	1.5	1.5	1.5	1.5	1.2	1.2	1.2	1.2	1.2	1.2
11	Lateral Earth Pressure Sat_ Ka	0	0	0	0	0	0	0	0	0	0
12	Vertical Surcharge Load	0	0	0	0	1.2	1.2	1.2	1.2	0	0
13	Surcharge load (Towards Right)	0	0	0	0	1.2	0	1.2	0	1.2	0
14	Surcharge load (Towards Left)	0	0	0	0	0	1.2	0	1.2	0	1.2
15	Surcharge load (Both Sides)	0	0	0	0	0	0	0	0	0	0
16	Water Pressure (HRL) (Lateral)	0	0	0	0	0	0	0	0	0	0
17	Water Pressure (HRL) (Vertical) Uplift case	0	0	0	0	0	0	0	0	0	0
18	Water Pressure at design water table level	0	0	0	0	0	0	0	0	0	0
19	Water Pressure at design water table level (uplift)	0	0	0	0	0	0	0	0	0	0
20	0.18 g Racking Point Force (Towards Right)	1.5	0	0	0	1.2	0	0	0	1.2	0
21	0.18 g Racking Point Force (Towards Left)	0	1.5	0	0	0	1.2	0	0	0	1.2
22	0.18 g Racking Distribution Force (Towards Right)	0	0	1.5	0	0	0	1.2	0	0	0
23	0.18 g Racking Distribution Force (Towards Left)	0	0	0	1.5	0	0	0	1.2	0	0
24	0.36 g Racking Point Force (Towards Right)	0	0	0	0	0	0	0	0	0	0
25	0.36 g Racking Point Force (Towards Left)	0	0	0	0	0	0	0	0	0	0
26	0.36 g Racking Distribution Force (Towards Right)	0	0	0	0	0	0	0	0	0	0
27	0.36 g Racking Distribution Force (Towards Left)	0	0	0	0	0	0	0	0	0	0

L/C No.		ULS SEISMIC (RACKING) CORRESPONDING TO 0.36g												
		2111	2112	2113	2114	2115	2116	2117	2118	2119	2120			
		Saturated soil												
Descriptions of Load Case		(MAX H - MIN V)	(MAX H - MIN V)	(MAX H - MIN V)	(MAX H - MIN V)	(MAX H - MIN V)	(MAX H - MIN V)	(MAX H - MIN V)	(MAX H - MIN V)	(MAX H - MIN V)	(MAX H - MIN V)	(MAX H - MIN V)	(MAX H - MIN V)	(MAX H - MIN V)
1	Self Weight	1	1	1	1	1	1	1	1	1	1	1	1	1
2	SIDL	1	1	1	1	1	1	1	1	1	1	1	1	1
3	Soil Back Fill	1	1	1	1	1	1	1	1	1	1	1	1	1
4	Live Load on concourse & platform	0	0	0	0	0	0	0	0	0	0	0.6	0.6	0.6
5	Train Live Load	0	0	0	0	0	0	0	0	0	0	1.2	1.2	1.2
6	Lateral Earth Pressure Sub (GWL @ HRL) K0	0	0	0	0	0	0	0	0	0	0	0	0	0
7	Lateral Earth Pressure Sub (GWL @ HRL) Ka	0	0	0	0	0	0	0	0	0	0	0	0	0
8	Lateral Earth Pressure Sub (GWL @ GL) K0	0	0	0	0	0	0	0	0	0	0	0	0	0
9	Lateral Earth Pressure Sub (GWL @ GL) Ka	0	0	0	0	0	0	0	0	0	0	0	0	0
10	Lateral Earth Pressure Sat_ K0	1.2	1.2	1	1	1	1	1	1	1	1	0	0	0
11	Lateral Earth Pressure Sat_ Ka	0	0	0	0	0	0	0	0	0	0	1	1	1
12	Vertical Surcharge Load	0	0	0	0	0	0	0	0	0	0	1.2	1.2	1.2
13	Surcharge load (Towards Right)	1.2	0	1	0	1	0	1	0	0	0	0	0	0
14	Surcharge load (Towards Left)	0	1.2	0	1	0	1	0	0	0	0	0	0	0
15	Surcharge load (Both Sides)	0	0	0	0	0	0	0	0	0	0	0	0	0
16	Water Pressure (HRL) (Lateral)	0	0	0	0	0	0	0	0	0	0	0	0	0
17	Water Pressure (HRL) (Vertical) Uplift case	0	0	0	0	0	0	0	0	0	0	0	0	0
18	Water Pressure at design water table level	0	0	0	0	0	0	0	0	0	0	0	0	0
19	Water Pressure at design water table level (uplift)	0	0	0	0	0	0	0	0	0	0	0	0	0
20	0.18 g Racking Point Force (Towards Right)	0	0	0	0	0	0	0	0	0	0	1.2	0	0
21	0.18 g Racking Point Force (Towards Left)	0	0	0	0	0	0	0	0	0	0	0	1.2	0
22	0.18 g Racking Distribution Force (Towards Right)	1.2	0	0	0	0	0	0	0	0	0	0	0	0
23	0.18 g Racking Distribution Force (Towards Left)	0	1.2	0	0	0	0	0	0	0	0	0	0	1.2
24	0.36 g Racking Point Force (Towards Right)	0	0	1	0	0	0	0	0	0	0	0	0	0
25	0.36 g Racking Point Force (Towards Left)	0	0	0	1	0	0	0	0	0	0	0	0	0
26	0.36 g Racking Distribution Force (Towards Right)	0	0	0	0	0	0	0	0	0	0	0	0	0
27	0.36 g Racking Distribution Force (Towards Left)	0	0	0	0	0	0	0	0	0	0	0	0	0

L/C No.	Descriptions of Load Case	SLS									
		Submerged Water @ GL					Saturated soil				
		3001	3002	3003	3004	3005	3101	3102	3103	3104	3105
		( MAX H - MAX V)	( MAX H - MIN V)	( MIN H - MAX V)	( MIN H - MAX V)	( MAX H - MAX V)	( MAX H - MAX V)	( MAX H - MIN V)	( MIN H - MAX V)	( MIN H - MAX V)	
1	Self Weight	1	1	1	1	1	1	1	1	1	1
2	STD L	1	1	1	1	1	1	1	1	1	1
3	Soil Back Fill	1	1	1	1	1	1	1	1	1	1
4	Live Load on concourse & platform	1	0	0	1	0	1	0	0	1	0
5	Train Live Load	1	0	0	1	0	1	0	0	1	0
6	Lateral Earth Pressure Sub (GWL @ HRL) K0	0	0	0	0	0	0	0	0	0	0
7	Lateral Earth Pressure Sub (GWL @ HRL) Ka	0	0	0	0	0	0	0	0	0	0
8	Lateral Earth Pressure Sub (GWL @ GL) K0	1	1	1	0	0	0	0	0	0	0
9	Lateral Earth Pressure Sub (GWL @ GL) Ka	0	0	0	1	1	0	0	0	0	0
10	Lateral Earth Pressure Sat_ K0	0	0	0	0	0	1	1	0	0	0
11	Lateral Earth Pressure Sat_ Ka	0	0	0	0	0	0	0	0	1	1
12	Vertical Surcharge Load	1	0	0	1	0	1	0	0	1	0
13	Surcharge load (Towards Right)	0	0	0	0	0	0	0	0	0	0
14	Surcharge load (Towards Left)	0	0	0	0	0	0	0	0	0	0
15	Surcharge load (Both Sides)	1	1	1	0	0	1	1	1	0	0
16	Water Pressure (HRL) (Lateral)	0	0	0	0	0	0	0	0	0	0
17	Water Pressure (HRL) (Vertical) Uplift case	0	0	0	0	0	0	0	0	0	0
18	Water Pressure at design water table level	1	1	1	1	1	0	0	0	0	0
19	Water Pressure at design water table level (uplift)	1	1	1	1	1	0	0	0	0	0
20	0.18 g Racking Point Force (Towards Right)	0	0	0	0	0	0	0	0	0	0
21	0.18 g Racking Point Force (Towards Left)	0	0	0	0	0	0	0	0	0	0
22	0.18 g Racking Distribution Force (Towards Right)	0	0	0	0	0	0	0	0	0	0
23	0.18 g Racking Distribution Force (Towards Left)	0	0	0	0	0	0	0	0	0	0
24	0.36 g Racking Point Force (Towards Right)	0	0	0	0	0	0	0	0	0	0
25	0.36 g Racking Point Force (Towards Left)	0	0	0	0	0	0	0	0	0	0
26	0.36 g Racking Distribution Force (Towards Right)	0	0	0	0	0	0	0	0	0	0
27	0.36 g Racking Distribution Force (Towards Left)	0	0	0	0	0	0	0	0	0	0

**OUTLINE DESIGN SPECIFICATIONS  
FOR  
BORED TUNNEL**

# **1 INTRODUCTION**

## **1.0 Brief Presentation of Project**

The Contract DCDD-01(R): Engagement of Detailed Design Consultant (DDC) for Civil, Architectural and Building Services including E&M works for Inderlok - Indraprastha (UG) and Majlis Park - R.K. Ashram (UG & Elevated) Corridor of Phase-IV of Delhi MRTS projects. This Design Manual summaries the proposed design criteria and other related parameters for the Bored tunnels related to civil, structural and geotechnical aspects (reference shall be made to Geotechnical Interpretative Report).

## **2 SCOPE OF DBR**

The scope of this DBR is for Bored Tunnels by TBM. The design basis report hereto provides minimum standards that are to govern the design. The design basis report shall be read in conjunction with the Outline Construction Specifications where appropriate.

The design of the permanent and temporary supporting works shall comply with code of practice and standards at the time of submission of Tender Documents, Regulations made and requirements issued by the DMRC and by related utility authorities shall be followed and specified

## **3 MATERIALS**

### **3.1 Cement**

- (1) Ordinary Portland cement (OPC) of 33 grade, 43 grade and 53 grade conforming to IS: 269, IS: 8112-1989 and IS: 12269-1987, respectively, shall be used.
- (2) Portland pozzolana cement (PPC) conforming to IS:1489 may also be used.
- (3) Sulphate- resistant Portland cement conforming to IS:12330 for structural elements exposed to soil may also be used.
- (4) For foundation and substructure, the Engineer may direct the OPC substitution by Blast Furnace Slag Cement confirming to IS:455.

### **3.2 Concrete**

- (1) The Density of concrete adopted shall be as below:
  - a. 24 kN/m<sup>3</sup> for prestressed concrete (IS:875 part-I table-1 item 21 value

- rationalized).
- b. 24 kN/m<sup>3</sup> for reinforced concrete with 2% or less reinforcement (IS: 875 Part-1 Table-1 item 22 value rationalized).
  - c. 25 kN/m<sup>3</sup> for reinforced concrete with above 2% reinforcement (IS: 875 Part-1 Table-1 item 22 value rationalized).
  - d. 23 kN/m<sup>3</sup> for plain concrete (IS:875 part-I table-1item 20).
- (2) Short term modulus of elasticity 'Ec, & Modular Ratio 'm' shall be as per clause no. 6.2.3.1 & B-1.3 (d) of IS: 456 respectively.
  - (3) Minimum grade of concrete shall be M35.
  - (4) Thermal Expansion Coefficient:  $1.17 \times 10^{-5}$  / °C (Cl.2.6.2 IRS Bridge Rules).
  - (5) Poisson's Ratio: 0.15 for all concretes.
  - (6) Minimum cement content 400 kg/m<sup>3</sup> and Maximum Water -Cement ratio 0.4 shall be considered.
  - (7) Strength of concrete is the specified characteristic compressive strength of 150 mm cube at 28 days.
  - (8) Minimum concrete cover as per IS: 456.

### **3.3 Reinforcement**

Only thermo-mechanically treated reinforcement bars conforming to IS:1786 shall be adopted. (For seismic zone III, IV & V with minimum total elongation of 14.5%).

### **3.4 Structural Steel: General**

- (1) Design of Structural steelwork shall comply with IS: 800.
- (2) Two types of structural steel to be used and shall comply with the following standards:
  - a) IS: 4923 "Hollow steel sections for structural use with  $Y_{st}$  310".
  - b) IS: 2062 "Steel for General Structural Purposes (Grade B-Designation 410-B)".
- (3) Hollow steel sections shall be square (SHS) or rectangular (RHS). Other traditional rolled sections like plates, angles, channels, joists can also be used where required.
- (4) The connection with concrete shall be effected by internally threaded bolt

sleeves (hot dipped galvanized @ 300 grams per square metres) manufactured from IS:2062 Grade B mild steel. The sleeve shall receive hexagon-head bolt M20 Class 8.8 as per IS:1364 (Part 1) with galvanized spring washer.

- (5) The connections within the steel structure shall be designed as direct welded members with or without gusset plates. The minimum thickness of metal for SHS/RHS sections for main chord members as well as bracings shall be 4 millimetres as applicable for steel tubes in cl. 6.3 of IS: 806.

### 3.4.1 Material Properties

Material Properties shall be as follows:

Steel Type	Young's Modulus	Tensile Strength	Yield Strength	Density	Poisson's Ratio	Thermal Expansion Coefficient
For Hollow Steel Sections (Conforming to IS: 4923)	200000 Mpa	450 Mpa	310 Mpa	78.5 kN/m <sup>3</sup>	0.30	1.2x10 <sup>-5</sup> Per °C
Structural Steel (Conforming to IS: 2062)		410 Mpa	250 Mpa (for t<20mm), 240MPa (for 20mm < t < 40 mm), 230MPa (for t > 40mm)			

## 4 TUNNEL PROFILE, CONSTRUCTION METHODS

Unless otherwise advised by the Engineer the bored tunnel alignment shall follow the alignment shown on the Tender Drawings. The bored tunnels comprise twin single-track tunnels. The spacing between the tunnels shall be based on the soil strata and determined by numerical analysis. The minimum internal diameter for bored tunnel shall meet all services and SOD (Schedule of Dimensions) requirements. Bored tunnels in rock and soil will be excavated mainly using tunnel boring machines, other methods if required based on geological and hydrological condition to be decided. Initial tunnel support will generally include precast concrete segments, shotcrete/wire mesh, rock bolts, lattice girders, steel sets, or forepoles wherever necessary.

The design of the segmental lining shall be as per the following –

- 1 Austrian Society for Rock Mechanics: Geotechnical Underground Structures Design (Tunneling in Rock)
- 2 International Tunnel Association: Guidelines for the Design of Tunnels
- 3 Hashash, Y.M.A., Hook, J.J., Schmidt, B., Yao, J.J. (2001). Seismic Design and Analysis of Underground Structures, Tunneling and Underground Space Technology. 16, pp. 247-293.
- 4 Muir Wood, A.M. (1975): The Circular Tunnel in Elastic Ground (Closed form solution)
- 5 D.J. Curtis et al (1976): Discussion Paper - Circular Tunnel in Elastic Ground.

The analysis Will be carried out by using Geo-technical FEM Software to verify the Hoop forces and Moments. Validation of used software shall be provided.

## **5 DESIGN LIFE/ DESIGN SPECIFICATIONS / REQUIREMENTS / PRINCIPLES**

### **5.1 Design Life**

Main Structure resisting ground and groundwater loads	100 Years
Non-structural components	50 Years

### **5.2 Tunnel Design**

- (1) The design of the bored tunnel shall be fully compatible with the construction methodology and shall be carried out using suitable software.
- (2) The design shall also take into account all expected loads prescribed in item no.6.
- (3) The design shall take into account all additional loads, stresses and strains imposed by or on adjacent Existing Building Structures (EBS) and assumed distortions and loads by or on the proposed bored tunnel.
- (4) Where bored tunnels are adjacent to or beneath EBS, the design shall demonstrate that these EBS shall not be subjected to unacceptable movement, distortion or loss of support which endangers the stability of the EBS and that any resulting movements and distortions will be within prescribed limits determined by the authority for that EBS, the Employer's Representative, or the Owner.
- (5) The Designer shall ensure that ground movements and distortions, and changes to the loads and piezometric pressures which may affect adjacent EBS either at surface

or underground, are within the allowable tolerances for each of those EBS.

- (6) The design shall consider and minimise the short- and long-term influence of the bored tunnels on the groundwater regime, and similarly the influence of the groundwater on the bored tunnels.
- (7) During tunnelling, Designer to constantly review the ground conditions based on envisaged and actual condition encountered, to allow excavation to be carried out in the safest and most efficient manner. This review shall be fully integrated into the construction risk control and should typically include:
  - a) Probing ahead of and around the bored tunnel face in ground conditions.
  - b) Interpretation of fresh data and correlation with previous information.
  - c) Prediction of ground conditions likely to be encountered.
  - d) Investigation on the surface for the presence of water wells/ bore wells for domestic use in residential areas that intersect the alignment.
- (8) Ground Information from all construction activities shall be collated and interpreted.

### **5.3 Tunnel Lining segment**

- (1) The design of the segments shall be adequate for all stresses induced during stacking, lifting, transport, erection jacking and impact, including in-service stress & impact.
- (2) The design shall consider in-situ ground stresses and shall provide evidence and/or measurements in support of the parameters adopted in the design as part of the calculations. The ground load on the tunnel shall be based on the actual height of overburden above the tunnel lining.
- (3) The design of the bored tunnel linings shall take into account the proximity of the bored tunnels one to another, the sequence and timing of construction and the proximity of adjacent EBS.
- (4) The design shall also consider the relative rates of loading / unloading due to TBM jacking force in both the lateral and vertical directions, and the resultant induced tunnel deformations whether temporary or permanent.
- (5) The segment has to be designed for 2hr fire rating as per IS:456.
- (6) The design method shall take into account the interaction between the lining and the ground, the deflection of the lining and the redistribution of the loading dependent upon the relative flexibility of the lining, the variability and compressibility of the ground.

- (7) The designer shall consider and conform to all durability aspects of the permanent bored tunnel lining including permeability/transmissivity and electrical resistivity.
- (8) The design shall take into account the proximity of the lining to the tunnel face at the time of installation and the potential for additional ground loads as the face advances.
- (9) The design shall allow for the expected variation in ground conditions and the size, proximity, timing and method of construction of adjacent excavations. The lining flexibility shall make due allowance for likely deflection of the lining during construction and operation.
- (10) Where a permanent or secondary lining is to be installed inside a temporary or primary lining, the ground loads used in permanent lining design shall consider all loads as described in the Contract and any additional ground loads that may arise from time-dependent ground strains.
- (11) The stiffness of the permanent lining should be such that the deflections are within permissible limits as per BS: 8110-part1 and IS:456.
- (12) The thickness of segments shall suit the method of construction and shall not be so large that part shoving of the shield becomes a general necessity.
- (13) The thickness of the segments shall be consistent with the capacity of the circle bolting arrangements to withstand the shear forces induced in linings built with staggered joints and for the planned reinforcement and required concrete cover.
- (14) Gasket detail shall be as per Technical Specifications.
- (15) A groove for post-construction grouting/caulking as necessary shall be provided on the intrados for each segment joint.
- (16) The lengths of segments shall be chosen with regard to bending stresses during handling, storage and erection and the long-term stresses due to ground loading and the resultant deflections.
- (17) The design of linings shall include tapered rings in order to negotiate the alignment curvature and to correct for line and level during construction with the minimum use of circumferential joint packers consistent with attaining the required degree of water-tightness of the bored tunnels in accordance with the contract.
- (18) The design for segment lining shall address aspects including the following, as appropriate
  - a) Ring configurations,

- b) Segment size and form,
- c) Fixing details including for:
  - ring to ring fixings;
  - segment to segment fixings;
  - fixings for all equipment to be installed
  - handling, stacking and installation of segments;
  - holes, recesses and fixtures for other system components.
- d) tolerances in production and installation of segments shall be accounted in the design.
- e) Installation of Other components, such as:
  - grout hole valves;
  - gaskets;
  - bedding and packing materials.
- f) Cavity grout, between lining and ground.
- g) Instrumentation and monitoring to demonstrate performance of the installed linings.
- h) Short-term {during construction} intermediate (immediately after construction) and long-term (full design life) loading conditions.
- i) Stresses induced by grouting and ground pre-treatment, where applicable.

## **6 DESIGN LOADS AND LOADING CONDITIONS**

### **6.1 Loads**

The method of analysis shall consider in situ ground stresses and shall provide evidence and/or measurements to the Engineer in support of the parameters adopted in the design.

Analysis shall be undertaken of the additional ground loadings imposed by adjacent structures on the underground structures and due account taken of the additional stresses in the design of the underground structures.

Where the tunnels are adjacent to buildings and other structures, analysis shall be provided to ensure that no loss of support can occur which endangers the stability of the buildings and structures and that settlement will be within specified limits.

All tunnel sections shall have permanent, durable, structural linings, generally consisting of bolted steel segments, pre-cast concrete segments, or cast-in-situ, plain or reinforced concrete.

Linings shall be designed to withstand all environmental loadings, distortions and other effects without detriment. In general, bored tunnel linings shall be designed to fulfil the following requirements and to resist the following loads:

- a) Dead Load
- b) Superimposed surface loads from traffic, existing structures over and adjacent to the bored tunnel, and any specified future loads
- c) Appropriate ground loads, water pressure, and seismic loads
- d) Railway loads where appropriate
- e) Long- and short-term ground yield or squeeze
- f) Unequal grouting pressures.
- g) Adjacent bored tunnelling or excavation
- h) Long- or short-term loads induced by construction
- i) Temperature and shrinkage
- j) Handling loads, including impact, especially in the case of unreinforced segments
- k) Jacking forces, where appropriate.
- l) Accidental loading such as fire and derailment.

## **6.2 Loading Conditions**

The design of the linings for the tunnels shall be fully compatible with the Contractor's proposed method of construction. The principal method is expected to be shield driven tunnel (TBM) with permanent precast concrete lining.

The design shall also take into account all loadings, the requirements of the overall schedule, the need for further investigations as necessary, and contract limitations with regard to ground movements and de-watering.

The tunnel alignment shall generally follow the alignment shown on the Tender Drawings.

All components of underground structures shall be proportioned to withstand the applied loads and forces as follows:

- a) Dead load comprises the self-weight of the basic structure and secondary elements supported and the weight of earth cover. The depth of cover shall be the actual depth or minimum one diameter of tunnel. The depth of cover shall be measured from the ground surface to the tunnel crown.
- b) Traffic surcharge shall be as per the loading of IRC/IRS as applicable.
- c) Loads from existing or known future adjacent structures above or within the area of influence, which will remain in place above the bored tunnels, or any specified future loading. The applicable foundation load and its influence shall be computed based on the type and use, and the foundation type which supports that structure.
- d) Additional support, ground treatment or additional lining thickening shall be provided unless it can be shown that adequate provision already exists. Any structure surrounding tunnel should be supported by grouting and shotcreting techniques, should not be supported from tunnelling.
- e) Where provision for a specific future structure is not made a minimum uniformly distributed surcharge of 60 kilo-Pascal at the design finished ground level shall be assumed.
- f) Hydrostatic pressure, ignoring pore pressure relief arising from any seepage into the tunnel. Both Water at ground level and minimum water/dry condition to be considered for design.
- g) Loads and load changes due to known construction activity In the vicinity of the bored tunnel, such as the excavation and the formation of underpasses, basements, pile groups, bridges, diaphragm walls and cable ground anchors.
- h) The grouting pressure will not exceed the hydrostatic pressure by more than 1 bar, however the actual pressure will be decided by in-charge chief Engineer based on the geological conditions.
- i) Structural requirements for resisting buckling is to be checked since tunnel is being designed as compression member.
- j) Additional loads / stresses in adjacent rings due to openings at cross passages locations to be considered.

### **6.3 Floatation**

For floatation check, the water table is assumed to coincide with the ground level. Where the bored tunnels are relatively shallow they shall be checked for the possibility of

flotation due to differential water pressure at representative typical locations. Uplift due to displaced water to be considered in the design. The overall factor of safety against flotation shall not be less than 1.1 for any of the condition.

#### 6.4 Crack Width

All structural concrete elements shall be designed to prevent excessive cracking due to flexure, early & long-term age thermal shrinkage. Flexural crack width shall be checked in accordance with Appendix F of IS: 456. The limits specified in d.35.3.2 of IS:456 has to be followed.

#### 6.5 Load Cases, Load Factors and Combinations

All analysis shall clearly show the designs achieve the design factors of safety.

##### 6.5.1 Load Cases

The following load cases will be considered at each design section:

- (i) Load case-1: Ground water table at the ground surface with uniform surcharge of 60 KN/m<sup>2</sup>
- (ii) Load case-2: Ground water table at the ground surface with no surcharge.
- (iii) Load case-3: No ground water with uniform surcharge of 60 KN/m<sup>2</sup>
- (iv) Load case-4: No ground water with no surcharge.
- (v) Load case-5: Ground water table at extreme water level with no surcharge.

##### 6.5.2 Load factors and Combinations

The design forces will be derived based on the following load factors.

Load Combination	Dead Load (DL)		Imposed Load (IL)		Ground and Water Loads		Seismic Load <sup>4</sup> (EQ)
	Adverse	Beneficial	Adverse	Beneficial	Adverse	Beneficial	
1. DL + IL	1.5	-	1.5	-	1.5	-	-

2. DL + EQ	1.5	0.9	-	-	-	-	1.5
3. DL + IL + EQ	1.2	-	1.2	-	1.2	-	1.2
4. Collision/ Accidental	1.5	1.0	1.5	-	1.5	1.0	-

Notes :-

1. Load Combination 4 will be used in checking temporary works proposals and checking the structure during temporary construction stages. The imposed load is the construction-imposed load.
2. For checking structures at the extreme water levels, the reduced partial factors of safety for water loads are to be 1.1.
3. Structural steel design load combinations and partial factors of safety for the design of structural steelwork are to be in accordance with IS 800-code of practice for the structural use of steel work.
4. Earthquake loads are reversible.
5. 50 % imposed load is to be used in line with the building mass calculated for seismic loads in load case 2 & 3.
6. Creep, shrinkage, temperature and differential settlement are not considered in combination with the lateral loads at ultimate limit state. Creep and shrinkage effects will usually be minor for building type structures, no specific calculation will be necessary for ultimate limit state.
7. (\*\*) For those structural members which are load bearing during the construction stage and subsequently form part of the permanent Works, the serviceability Limit State (SLS) checks shall be carried out both for "Construction" and "Service/optional" stages.

Load factors for SLS Cases

Load Combination	Dead Load	Imposed Load	Ground & Water Loads
1. DL+IL	1.0	1.0	1.0
2. DL+EQ	1.0	-	-
3. DL+IL+EQ	1.0	1.0	1.0

## 7 GENERAL CONSTRUCTION METHODS

- (1) Initial ground support for the bored tunnels is expected to comprise ground pre-treatment (where necessary) and/or precast concrete segments.
- (2) Methods for excavation, spoil removal, ground treatment, installation of initial support and the permanent lining construction to be prepared.
- (3) Excavation shall be carried out in a uniform and controlled manner, over-cutting shall be kept to a minimum.
- (4) Appropriate methods and necessary steps to be taken to control flows and movement into, and to maintain the stability of the excavation.
- (5) Instrumentation and monitoring arrangements for ground and existing building

structures (EBS) movement and distortion and changes to the groundwater table(s) and the trigger (Alert, Action & Alarm) levels for each and every identified EBS to be performed. Designer has to specify the required instrumentation and monitoring arrangement to maintain the safety of the EBS.

## **7.1 Tunnel Lining – General**

### **7.1.1 Tunnel Lining -Temporary Support**

- (1) Steel sets and lattice arch girders shall be rolled to suit the dimensional requirements of the designed opening. The Contractor shall provide dimensional details of the steel sets or lattice arches girders and lagging which include all calculations regarding imposed loads before and after any ground pre-treatment.
- (2) S-piles shall be steel rods or tubes of outside diameter not less than 32 millimetres.
- (3) Pipe piles shall be steel tubes of outside diameter not less than 100 millimetres.
- (4) Rock dowels shall be un-tensioned steel bars threaded at one end and provided with a face plate, shim plates and a conical seated washer and nut, or split or deformed steel tubes, or glass fibre reinforced resin rods.
- (5) Rock bolts shall be tensioned bar manufactured out as one of the following types - solid steel bar, slit or deformed steel tube, glass fibre reinforced resin rods.
- (6) Alternative materials shall be subject to the notice of the Employer's Representative.

### **7.1.2 Tunnel Lining - Permanent Support**

- (1) The permanent bored tunnel support or lining shall generally comprise segmental spheroidal graphite iron (SGI) or precast concrete (plain or reinforced) rings that are held securely in place and the same will remain so for all known possible future conditions.
- (2) The internal diameter shall take account of the need to accommodate the Structure Gauge, and the track bed arrangement to be provided by the Trackwork Contractor.
- (3) The stiffness of the lining shall be sufficient to limit the maximum allowable deflection to on radius to 25mm. The distortional loads adopted shall also take account of the speed of reloading of the horizontal and vertical ground pressure and in the case of the shallow tunnels, the ability of the ground above the tunnel to generate sufficient passive resistance to maintain stability of the lining.
- (4) Stresses induced by grouting
- (5) Exceptions to these permanent linings may be at cross-passages (links between

tunnels), enlargements of the bored tunnel and at the junction between cut-and-cover and bored tunnel sections. In such locations cast-in-place linings shall be used, or alternative types of permanent lining may be proposed subject to the notice of The Employer's Representative.

- (6) The reinforcement for segmental concrete lining shall be detailed such that there is no electrical continuity across the circle joints. To prevent the stray current effects and to inhibit the corrosion, suitable property enhancers shall be added in to concrete. Such concrete shall be tested in accordance with ASTM C 1202 and DIN 1048. SGI lining segments and all concrete reinforcement shall be bonded to mitigate stray currents. The bonding shall be part of the corrosion control system designed and installed by the Contractor to the notice of the Employer's Representative. The corrosion control system shall be tested and proven to the satisfaction of the Designer that the corrosion control system functions as designed in all locations.
- (7) Blind holes and other fixings shall be necessary for the installation of internal construction, brackets and equipment, Such holes or fixings shall be detailed such that they have no adverse effect on the integrity, water tightness or design life of the linings.

### **7.1.3 Gasket Grooves**

Gasket grooves shall be provided around all joint faces of each segment and key in accordance with the dimensions as approved by the engineer in charge. The design shall incorporate sealing gaskets in the segmental design.

### **7.1.4 Grout holes**

Grout holes shall be provided in segment as per design excluding the key, and shall be of a nominal 50 mm diameter.

### **7.1.5 Waterproofing**

During construction in water bearing ground, the seepage water shall be controlled by suitable means and design should provide for the same. The Contractor shall obtain the Engineer's prior agreement to the process he intends to adopt. Pumping of large quantities of water such that the piezometric pressure in the vicinity is within permissible safe limits and contractor is required to get permission from related authority.

Groundwater leakage rates shall not exceed 0.1 litre/m<sup>2</sup>/day and 0.2 litres/m<sup>2</sup>/day for segmental lining and in-situ lining respectively. For any 10m length of tunnel the water ingress rate shall not exceed 0.2 litre/m<sup>2</sup>/day and 0.4 litres/m<sup>2</sup>/day for segmental lining and in-situ lining respectively.

The design shall incorporate two sealing gaskets in the segment design. Materials for sealing gaskets shall be one gasket of hydrophilic material and one gasket of elastomeric type. Materials shall have acceptable fire performance for use on an underground railway.

Notwithstanding the above limits on groundwater leakage rates, the design shall aim to ensure that no loss of ground occurs through any part of the structure.

#### **7.1.6 Cavity grouting**

General purpose cement grout with suitable admixture shall be mixed in accordance with the proposed design mix and purpose of use. Grout shall be used within one hour of mixing.

#### **7.2 Underpinning of Existing Structures**

Where the construction of tunnels or other underground works would necessitate removal of existing support or foundations to existing structures the Contractor shall carry out investigations of the extent of the existing works, their design and loading conditions. The Contractor shall design and carry out such works as are necessary to maintain the integrity of the structure at all times including its design life. No work shall commence prior to the consent of the Engineer being given. Cost of design and provision of any support/strengthening of such structures will be deemed as included in the Contractor's Price.

### **8 CROSS-PASSAGES**

- (1) Where tunnelling is carried out not using TBM (ie, by hand or face excavator) temporary support using pipe piles, spiles, structural-steel sets, lattice-arch girders, base-plates, ties and connections and lagging sprayed concrete (shotcrete) or cast-in-place concrete all of which comply with the relevant standards may be used together with appropriate ground pre-treatment as deemed necessary for the expected ground conditions.
- (2) Passenger emergency evacuation design for cross-passages between running tunnels which are constructed by either cut-and-cover or bored method shall generally be in accordance with the requirements of NFPA 130 2010 6.2.2.3.2.
- (3) The openings into the running tunnels shall have a width of 1.2 metres and a height of 2.1 metres. Throughout the cross-passage the minimum headroom of 2.1 metres shall be maintained over a width of 1.2m.
- (4) The cross-passage floor screed shall be laid to fall and drain into the running tunnel drainage system. Floor level shall correspond with the level of the bored tunnel escape

route.

- (5) A concrete bulkhead fitted with steel door and frame shall be constructed to isolate the cross-passage from each running tunnel. This door shall be self-latching, have a fire resistance of 2 hours minimum and shall be capable of withstanding the maximum differential pressures on either side created by the passage of trains. The maximum force to open the door shall be as per NFPA 130 2010 6.2.2.4.2.
- (6) The cross-passage permanent lining shall comprise concrete lining designed generally in accordance with the requirements of these documents with the following exception that the maximum allowable deflection on radius shall be as per IS:456 clause 23.2(b).
- (7) The junctions with the running bored tunnels shall be steel-framed and encased with concrete. The junctions shall be designed to fully support the running tunnel linings at the openings together with the ground and groundwater loads on the junction itself.
- (8) The cross-passages and junctions shall comply with same water-tightness criteria as the bored tunnels.
- (9) Where openings for cross-passages and the like are to be formed in running tunnels with segmental concrete or SGI linings, temporary internal supports to the running tunnel lining shall be provided. These supports shall adequately restrain the ground and lining such that on completion of the openings and removal of the temporary supports the total deflection of the linings in either the opening, junction or running tunnel and water ingress do not exceed the limits.

## **9 TUNNEL WALKWAYS**

The Contractor shall be responsible for the design, provision and installation of a tunnel emergency evacuation walkway throughout bored and cut and cover tunnels. The location of the walkway shall be determined to provide a generally continuous walkway to permit emergency evacuation at any point in the tunnel. For a tunnel linking a side platform station to a central platform station the tunnel walkway can only provide continuity at one end. At the other end a fixed stairway shall be provided to track level to enable maintenance staff to cross the track to the platform end steps.

The walkway shall provide a durable non-slip surface set to a fall away from the track at the same level to the platform. The walkway shall be minimum 600 mm wide and provide a 600 mm wide X 2000mm high walkway space clear of fixed equipment. The detail of walkway is specified in tender drawings.

The Contractor shall liaise with the Designated Contractor to determine the setting out dimension from track centre line.

The design shall permit maintenance access to tunnel services mounted below the walkway and allow for ducts and/or pipes to pass from below to above walkway level without impinging on the 600mm clear width.

The walkway shall be designed for a uniformly distributed load of not less than 5.0kN/m<sup>2</sup> and shall be securely fixed to resist the effects of passing trains and movement of passengers and emergency services personnel. The design life shall not be less than 50 years.

Metal components such as bearers or handrails shall be provided with stray current corrosion protection as required. Particular attention shall be paid to step voltage from the Rolling Stock to earth for the protection of passengers

## **10 TUNNEL BORING MACHINES**

The TBM shall be robust with adequate safety margins for the anticipated duty, designed and manufactured to comply with all safety standards. The TBM procured must be capable of efficient excavation and installation of support within the expected site and ground conditions. This includes soil, rock, soil/rock mixture and existing EBS (notably wells) all mainly below the groundwater table.

General design requirement of TBM.

- a) TBM design shall ensure that the cutter-head can be retracted back from the unexcavated ground to minimise the risk of the TBM jamming and to facilitate maintenance.
- b) TBM design shall make adequate provision for the safety of the workmen and the application of safe methods of tunnelling.
- c) TBM shall be designed for and equipped with a supplemental ground stabilisation system. This system shall comprise regularly spaced grout ports built into the shield for drilling into and grouting the ground ahead of the tunnel face. The location and number of ports shall be adequate for implementation of face stabilisation measures needed for access to the face in all ground conditions. All ports shall be readily accessible and fitted with valves.
- d) TBM shall be designed to enable the void between the segment lining and the ground (tunnel extrados) to be grouted continuously from the shield as the shield is propelled forward by synchronised operation. TBM design shall allow control of the grouting volume, pressure and pipes to be cleaned in the event of a blockage. Grout pipes shall be

integral within the thickness of the TBM tail-skin. A minimum of four (4) separate grout pipes shall be provided. External grout pipes will not be permitted.

- e) The TBM shall be designed to maintain a pressure on the excavated ground at all times. This pressure shall at-least balance the in-place soil and hydraulic pressures making up the total overburden pressure and shall be capable of varying the face pressure as the overburden pressure changes. The design shall also take into account the soil type, density, gradation, strength and abrasion.
- f) The Contractor shall provide and maintain a complete list of the names of persons and their duties, responsible for the operation of the machine, who have completed the appropriate training to an accepted standard. A Certificate of Competence shall be provided by the Contractor.

**For TBM breakthrough in launching / retrieval shafts, soft eye should be used with Fibre Reinforcement only.**

## 11 DRAINAGE ARRANGEMENT IN RUNNING TUNNELS

- (1) The Designer shall coordinate with the adjacent station plumbing design before finalising the design for drainage arrangement and sump location.
- (2) The reserve capacity of a groundwater seepage sump shall be calculated on the basis of the area of bored tunnel lining applicable to the sump in accordance with the following formula.

$$V_R = A * v * t * F.O.S. * 10^{-3}$$

Where,

$$V_R = \text{Volume of reserve, m}^3$$

$$A = \text{Bored tunnel lining area, m}^2$$

$$v = \text{Maximum leakage rate, l/m}^2/\text{day}$$

$$t = \text{Maximum response time, (day)}$$

$$F.O.S = \text{Factor of Safety}$$

- (3) For running tunnel lows, point sumps the response time "t" shall be 24 hours and the factor of safety shall be 1.5.
- (4) The sump design shall include outlets for the longitudinal drain pipe and discharge mains, pumps of suitable capacity and power connection. Sumps shall be fitted with steel covers and provided with step irons or access ladder. Permanent discharge mains shall be

installed as well as embedment of conduits for permanent electric power cables to the pumps.

- (5) The linings of the sumps shall be designed for the appropriate ground and groundwater loads.

## **12 SETTLEMENT AND BUILDING PROTECTION**

### **12.1 General**

The Contractor shall design both his temporary and permanent works to ensure that ground movements at the ground are kept to an absolute minimum. The Contractor shall use proven techniques. Good workmanship is essential to restrict ground loss.

The Contractor shall be responsible for the control of all ground movements and for any resulting damage to buildings, bridges, tracks and roads. The Contractor's attention is drawn to the General Conditions of Contract and Employer's Requirements relating to repair of damage should any arise as a result of the Contractor's construction activities.

The Contractor shall take due regard of the presence of utilities over and adjacent to the Works. The Contractor shall carefully and regularly monitor the ground adjacent to open cut excavations and along tunnel drives to determine the rate and magnitude of any settlements.

Settlement shall be limited such that any individual structure or buildings shall not suffer damage greater than "Slight" as defined in the Damage Classification Table 12.7.

Settlement to Important Structures, Bridges, and Heritage Buildings shall be limited to "Negligible" as defined in the Damage Classification Table 12.7.

The general approach to settlement control and building protection shall involve the procedures described below.

### **12.2 Prediction of Ground Movements**

The Contractor shall obtain consent from the Engineer for his proposed methods of supporting and predicting settlements adjacent to structures. Proven methods based on practical experience shall be used.

The Contractor shall provide predictive assessments of the anticipated ground movements when making submittal for consent of his proposed method of construction of particular

sections of tunnel.

### **12.3 Structure Condition Survey**

The Contractor shall undertake a condition survey of all structures within the zone of potential influence as determined by the Contractor's analysis which are anticipated to incur movements in excess of the action level for Stage 1 specified below. `Structures` includes all surface and sub-surface structures including historical monuments, buildings, bridges, roads, tunnels, utilities, culverts and sewers.

### **12.4 Assessment of Impact on Structures**

The Contractor shall provide an assessment of the effect of the predicted movement on all structures within the zone of influence.

Each building shall be categorised into one of the risk categories, in accordance with criteria listed in column of the Damage Classification Table 12.7.

Depending upon the level of risk, precautionary and protective measures shall be proposed by the Contractor and put into effect after consent from Engineer.

### **12.5 Staged Assessment**

Assessment of the effects of settlement shall be undertaken in one, two or three stages, depending upon the findings at each stage, as described below: -

#### **Stage 1**

The effect of building foundations on the pattern of settlement is ignored. Any structure where the predicted settlement is less than 10mm and the predicted ground slope is less than 1/500 need not be subject to further assessment. All other structures within the zone of influence shall be subjected to a Stage 2 assessment.

#### **Stage 2**

Structures subject to settlement from bored tunnels shall be individually assessed using a limiting tensile strain approach. This method of assessment takes into account the tensile strains in the ground and uses a simple idealised model of the building. Tried and tested references from the literature may be utilised as an alternative.

In the case of cut and cover excavations, the assessment shall be based on the work of Peck and Clough and O'Rourke using parameters derived from recent case histories or any other tried and tested method.

### **Stage 3**

All structures which are placed in Category 3 or above in the Damage Classification Table 12.7, during the second stage assessment, shall be subjected to a further settlement assessment. A structural survey shall be undertaken by the Contractor to determine the structural form and condition of a building, followed by an analysis of how individual elements of the building would be affected by the predicted settlement. The method, extent and detail of the analysis will be determined on a case-by-case basis and may include, inter alia, an analysis of the soil/structure interaction, structural behaviour, and the possible effects of differential stiffness of the foundations.

As a result of the Stage 3 analysis, the requirement for any protective works shall be established and the details of any protective works including designs and method of working determined. Details of such works shall be submitted to The Engineer for his consent.

## **12.6 Monitoring**

Instrumentation and monitoring arrangements for ground and existing building structures (EBS) movement and distortion and changes to the groundwater table(s) and the trigger (Alert, Action & Alarm) levels for each and every identified EBS to be performed. Designer has to specify the required instrumentation and monitoring arrangement to maintain the safety of the EBS.

The extent of monitoring of structures shall be carried out on a case-by-case day to day or more frequent basis depending upon the assessment of risk of damage. Special attention shall be paid to the historical buildings located along the alignment. Monitoring shall begin prior to commencement of the Works to enable base-line values to be determined accurately and shall continue until all settlements due to the underground works, as shown by the monitoring, has effectively stopped for a period of three months.

The Contractor shall make monitoring results available for inspection by The Engineer at the construction site offices.

## 12.7 BUILDING DAMAGE CLASSIFICATION

Building Damage Classification <sup>1</sup> (after Burland et al, 1977 and Boscardin and Cording, 1989)				
1	2	3	4	5
Risk Category	Description of Degree of Damage	Description of Typical Damage and Likely Form of Repair for Typical Masonry Buildings	Approx <sup>2</sup> Crack Width( mm)	Max Tensile Strain %
0	Negligible	Hairline cracks.		Less than 0.05
1	Very Slight	Fine cracks easily treated during normal redecorations. Perhaps isolated slight fracture in building. Cracks in exterior brickwork visible upon close inspection.	0.1 to 1	0.05 to 0.075
2	Slight	Cracks easily filled. Redecoration probably required. Several slight fractures inside building. Exterior cracks visible : some repointing may be required for weather tightness. Doors and windows may stick slightly.	1 to 5	0.075 to 0.15
3	Moderate	Cracks may require cutting out and patching. Recurrent cracks can be masked by suitable linings. Tack-pointing and possibly replacement of a small amount of exterior brickwork may be required. Doors and windows sticking. Utility services may be interrupted. Water tightness often impaired.	5 to 15 or a number of cracks greater than 3	0.15 to 0.3
4	Severe	Extensive repair involving removal and replacement of sections of walls, especially over doors and windows required. Windows and door frames distorted. Floor slopes noticeably. Walls lean or bulge noticeably, some loss of bearing in beams. Utility services disrupted.	15 to 25 but also depends on number of cracks	Greater than 0.3
5	Very Severe	Major repair required involving partial or complete reconstruction. Beams lose bearing, walls lean badly and require shoring. Windows broken by distortion. Danger of instability.	Usually greater than 25 but depends on number of cracks	

### Notes:

- (1) The table is based on the work of Burland et al (1977) and includes typical maximum tensile strains for the various damage categories (column 5) used in the stage 2 settlement analysis.
- (2) Crack width is only one aspect of damage and should not be used on its own as a direct measure of it.

## 12.8 Limiting Construction-Induced Vibrations at Existing Adjacent Structures

In the design, the effects of construction-related vibrations shall be considered. Unless otherwise accepted by the applicable government agencies and the Employer, peak particle velocities at existing adjacent structures shall not exceed the values in the Table below:

Peak Particle Velocities in mm/sec (Maximum Allowable) at Existing Adjacent Structures

Most structures in "good" condition	25
Most structures in "fair" condition	12
Most structures in "poor" condition	5
Water-supply structures	5
Heritage structures/bridge structures	5

Above limits are maximum permissible, however this may have to be restricted further if required to avoid damage to the adjacent structure or causing discomfort to the occupants.

Along the proposed alignment, other limitations may be imposed at existing adjacent structures, such as hospitals, school buildings, telephone-exchange structures, special water-supply structures and Heritage structures.

Methods of reducing vibration, such as limiting explosive charge per delay or operating piledriving equipment at lower energy levels, may be required. The use of expansive agents or mechanical excavation methods shall be required in place of blasting at certain critical locations. In addition, working hours for such equipment's causing vibrations may have to be restricted, keeping the convenience and comfort of the occupants in mind.

## 13 LIST OF DESIGN CODES AND STANDARDS

Subject to the requirements of this specification and other Control documents, all design work shall comply with the appropriate current standards issued by the Bureau of Indian Standards (BIS), or if such a standard does not exist, then the appropriate current standard issued by the British Standard Institute (BSI). If appropriate standard from BIS and BSI does not exist, then subject to approval by engineer, an appropriate current standard from a reputable institution may be used. The designer shall follow updated codes with latest correction slips

**(Note:** the years of the codes mentioned below are notional, hence each time the designer shall adopt latest code with the latest correction slip)

The Order Preferences of codes will be as follows: -

- i. BIS
- ii. BSI or Euro Code
- iii. IRC
- iv. IRS
- v. AASHTO